

## PA Amplifiers

# EUROPOWER EPX2000/EPX3000

### EUROPOWER — Professional 3000/2000-Watt Light Weight Stereo Power Amplifiers with ATR (Accelerated Transient Response) Technology

- EPX3000: 2 x 1500 Watts into 2 Ohms; 2 x 900 Watts into 4 Ohms; 3000 Watts into 4 Ohms (bridge mode)
- EPX2000: 2 x 1000 Watts into 2 Ohms; 2 x 650 Watts into 4 Ohms; 2000 Watts into 4 Ohms (bridge mode)
- ATR (Accelerated Transient Response) technology for ultimate punch and clarity
- Ultra-light, ultra-low noise and ultra-efficient switch-mode power supply for noise-free audio, superior transient response and low power consumption
- Switchable limiters offer maximum output level with reliable overload protection
- Detented gain controls for precise setting and matching of sensitivity
- Precise Power, Signal and Clip LEDs to monitor performance
- XLR, ¼" TRS and RCA input connectors for compatibility with any source
- Professional speaker connectors and "touch-proof" binding posts support most speaker wiring systems
- Built-in Subwoofer/Satellite crossover for more flexibility
- Independent DC and thermal overload protection on each channel automatically protects amplifier and speakers without shutting down the show
- "Back-to-front" ventilation system including air filter for reliable operation
- "Built-like-a-tank"; impact-resistant, all-steel 2U rackmount chassis
- High-quality components and exceptionally rugged construction ensure long life
- Conceived and designed by BEHRINGER Germany



### Ultra-light, built on a legacy

Power amps have always been heavy, mainly because of the massive transformers and huge banks of capacitors needed for high-power operation. In fact, six conventional power amps in a rack can easily top 250 pounds. The same number of EPX Series amps come in at just under 134 lbs / 61 kg, and they pack all the power of their conventional counterparts!

### In a class of their own

The secret to the EPX series' incredible power-to-weight ratio is their use of a switching-mode power supply combined with Class-H topology. Switching-mode power supplies work on demand. Instead of constantly working at full power and dissipating excess power as heat, they only ramp up the power output when needed—thousands of times per

second. Considerably more efficient than traditional power supplies, switching-mode power supplies are small and light, yet deliver ample power.

Think of a Class H amp as a car with two engines (in amps, you call them "rails"). One engine runs all the time. The other runs only when musical peaks demand extra power output. An EPX Class H amp only generates a fraction more power than is immediately needed while the output stage operates at its maximum efficiency all the time.

And just like in today's hybrid cars, the efficiency of this dual system is far greater than having one engine or rail that must operate all the time. EPX amps don't waste power. Class H amps don't waste power, require much smaller heat sinks and much lighter power transformers.

*Continued on next page*

# EUROPOWER EPX2000/EPX3000

## Accelerated Transient Response delivers the knock-out punch

It takes huge pulses of energy (current and voltage) to propel a woofer cone out fast enough to match a bass beat. That's called Transient Response and it's the holy grail of amp designers. By carefully selecting transistors with extremely high slew rates and optimizing other proprietary parts of our circuitry, our amps are able to react instantly to even the most demanding electronic bass impulses. If the woofers in your PA system can keep up, your audience will hear a tighter, crisper, more natural sound.

Instead of operating relatively continuously like Class AB circuits, Class H amps, which were first described in NASA technology (U.S. patent 3,319,175), feature rail tracking for effectively modulating the power supply rails with only the peaks of the input signal. This technology has revolutionized pro audio amp designs with its outstanding performance and efficiency. When combined with switching-mode power supplies that replace heavy toroid transformers, our new designs provide more dynamic punch and, because they are so much more efficient, run cooler and don't require huge, heavy heat sinks.

BEHRINGER didn't invent Class H technology, but our R&D Department has been working for years to perfect our own version, creating lightweight amps that run cool and also achieve our goal of Accelerated Transient Response.

### Everything you need, nothing you don't

The simple front panel controls of these amps give you all of your sound's vital signs at a glance. After pressing the Power Button, the POWER LED will light when the amp is ready for action. Both channels have independent gain dials as well as clip LEDs that indicate when the signal is distorted and you need to reduce the gain. There are also SIGNAL LEDs that light up when a signal is present at the input.

### Panel discussion

The EPX series' INPUTs accept balanced XLR, 1/4" TRS, and unbalanced 1/4" TS and RCA connections. Take your pick of professional locking speaker outputs or touch-proof binding posts to securely connect speakers.

A panel of switches found on the back offers an array of cool options applicable to both channels. The Clip Limiter lets you get even more out of the amplifier without overdriving either it or your

*Continued on next page*

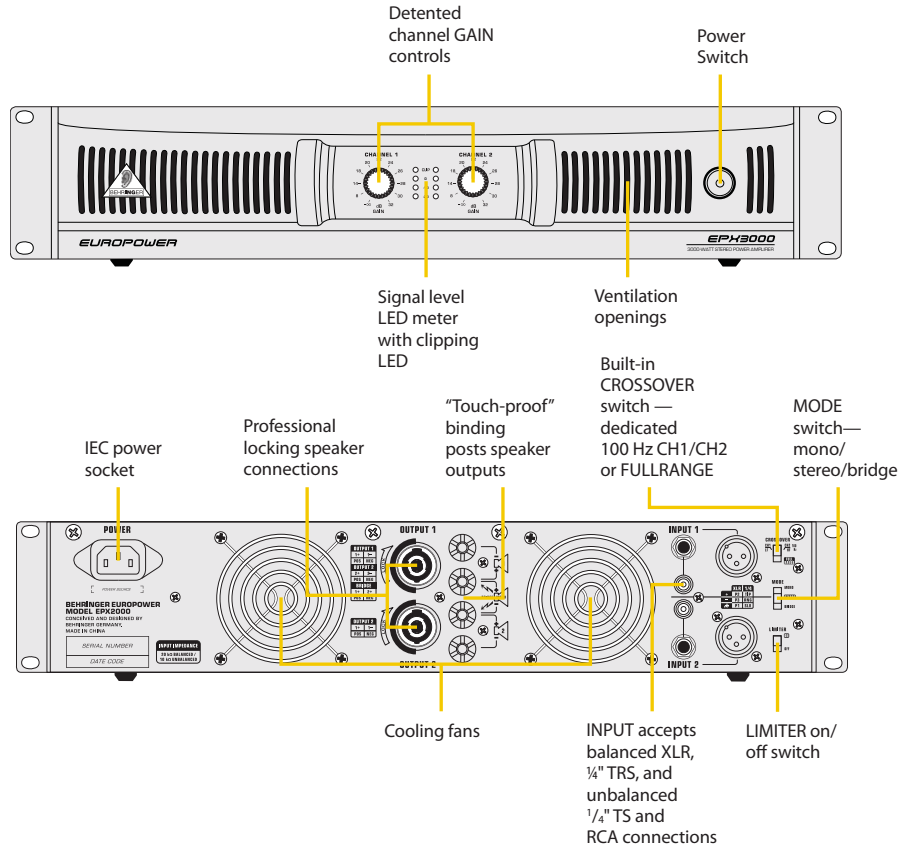

## Stereo Mode

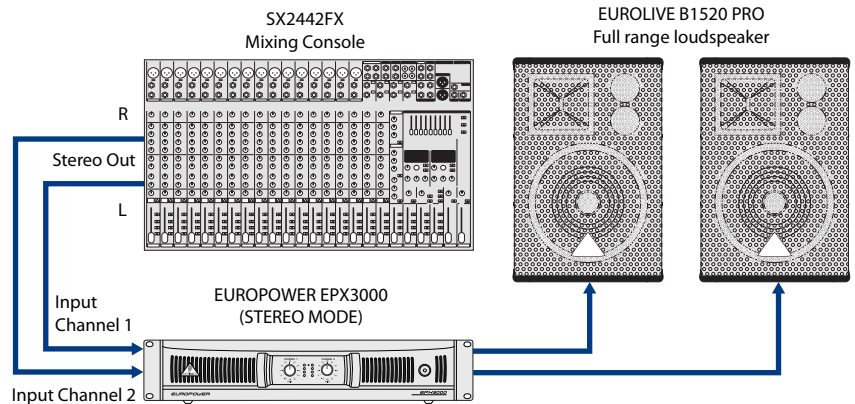

## Mono Mode

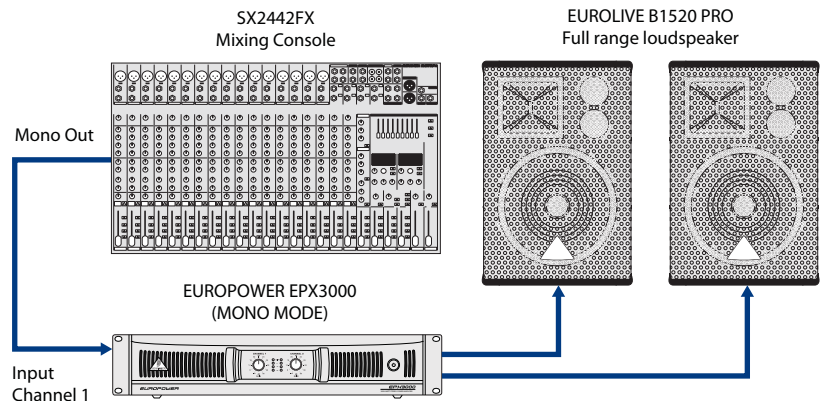

# EUROPOWER EPX2000/EPX3000

speaker system. Built-in circuitry automatically senses when the amp is being overdriven into "clipping" and then momentarily reduces the input level to avoid clipping distortion. This all happens in a few thousandths of a second, so it's an inaudible way of avoiding audible clipping distortion. Of course, you can turn the Limiter off if you're feeling lucky.

The same panel contains the switches that allow you to put these amps to work in either mono, stereo (two-channel mode) or bridge mode, which is always in mono. A built-in CROSSOVER switch lets you select the point at which highs and lows are separated (CH1 < 100 Hz / CH2 > 100 Hz or FULLRANGE).

BEHRINGER's EPX line is built for the working musician. It's much easier to transport than a conventional AB power amp, it packs ample power, it's got a

built-in crossover and limiter, and it's built to last through all the rigors of the road. Plus its light price tag will leave you with enough cash left over to acquire more stuff to amplify! Check out an EPX and find out why BEHRINGER power amps are among the most popular on Earth.

## Bi-Amp Mode

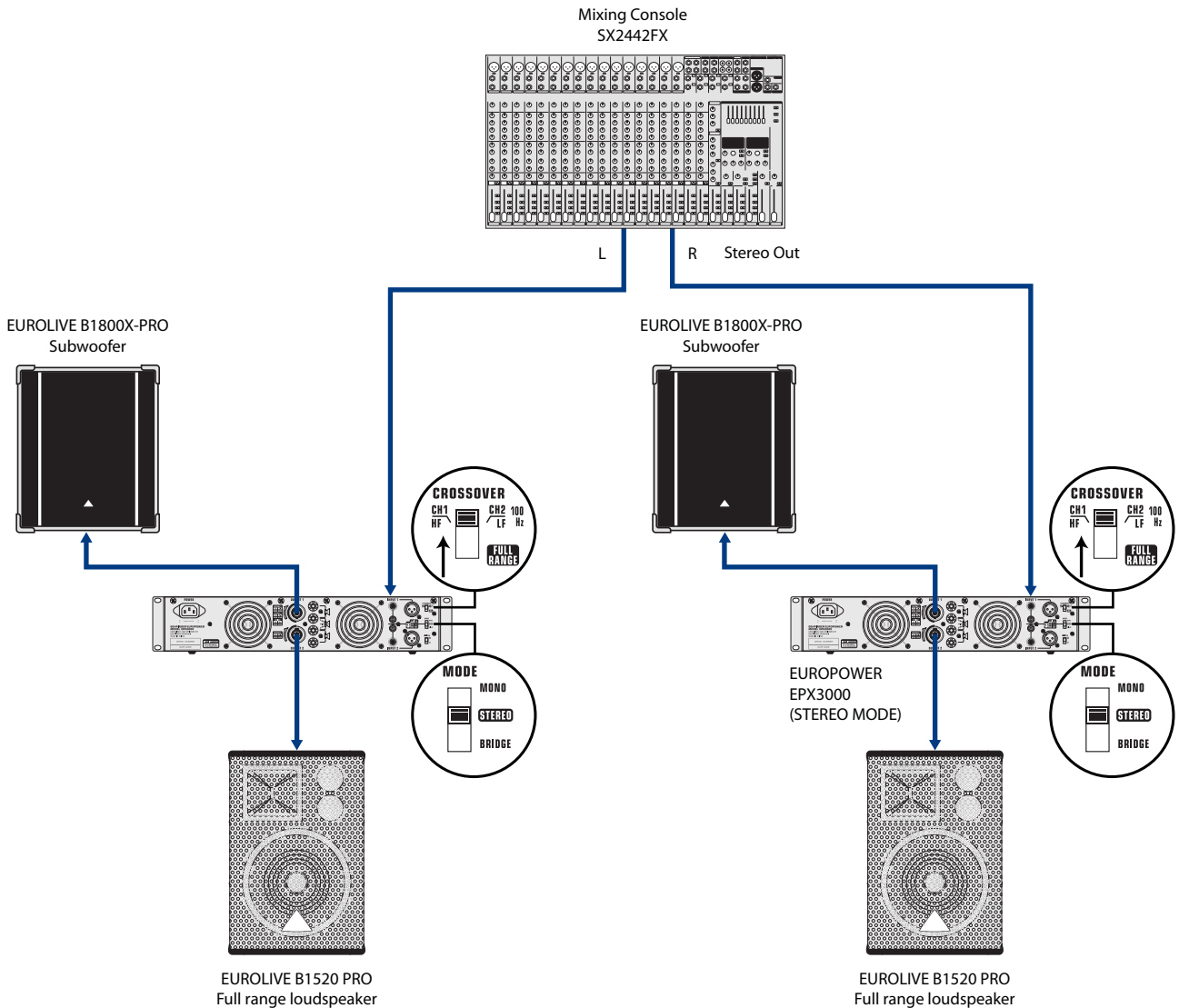

# EUROPOWER EPX2000/EPX3000

## OUTPUT POWER

### RMS Power

#### Stereo Mode (both channels driven)

#### EPX2000

8 Ω / 1 kHz @ 0.1% THD	350 W
8 Ω / 1 kHz @ 0.1% THD	600 W
2 Ω / 1 kHz @ 1% THD	1000 W

#### EPX3000

8 Ω / 1 kHz @ 0.1% THD	550 W
8 Ω / 1 kHz @ 0.1% THD	900 W
2 Ω / 1 kHz @ 1% THD	1500 W

#### Bridged Mono

#### EPX2000

8 Ω / 1 kHz @ 0.1% THD	1250 W
4 Ω / 1 kHz @ 1% THD	2000 W

#### EPX3000

8 Ω / 1 kHz @ 0.1% THD	1800 W
4 Ω / 1 kHz @ 1% THD	3000 W

### PEAK POWER

#### Stereo Mode (both channels driven)

#### EPX2000

8 Ω / 1 kHz	400 W
4 Ω / 1 kHz	800 W
2 Ω / 1 kHz	1450 W

#### EPX3000

8 Ω / 1 kHz	650 W
4 Ω / 1 kHz	1150 W
2 Ω / 1 kHz	2100 W

#### Bridged Mono

#### EPX2000

8 Ω / 1 kHz	1650 W
4 Ω / 1 kHz	2900 W

#### EPX3000

8 Ω / 1 kHz	2250 W
4 Ω / 1 kHz	4000 W

#### EPX2000/EPX3000

Input Sensitivity	1 V
-------------------	-----

## EPX2000/EPX3000

Distortion	<0.01%
------------	--------

## EPX2000/EPX3000

Frequency Response	20 Hz - 20 kHz, +0/-1 dB
--------------------	-----------------------------

## EPX2000/EPX3000

Voltage Gain	35 dB
--------------	-------

## EPX2000/EPX3000

Damping Factor	> 300 @ 8 Ω
----------------	-------------

## EPX2000/EPX3000

Input impedance	10 kΩ unbalanced, 20 kΩ balanced
-----------------	-------------------------------------

## EPX2000/EPX3000

Signal-to-Noise	> 100 dBA
-----------------	-----------

## EPX2000/EPX3000

### Controls

Front	POWER switch GAIN control (channel 1 and 2)
-------	---

Rear	MODE switch X-over Switch, BRIDGE MODE switch
------	---

## EPX2000/EPX3000

### Indicators

POWER	Blue LEDs
CLIP (per channel)	Blue LEDs
PROT (per channel)	Blue LEDs
SIGNAL (per channel) -20dB~-10dB	White LEDs
SIGNAL (per channel) -10dB~0dB	White LEDs

## EPX2000/EPX3000

### Connectors

Inputs	Balanced XLR, ¼" TRS, RCA
Outputs	Speakon and "touch-proof" binding posts

## EPX2000/EPX3000

### Circuit protection

Cooling	Continuously variable speed fan, back to front air flow
Amplifier protection	Full short circuit, open circuit, thermal, ultrasonic, RF protection. Stable into reactive or mismatched loads

## EPX2000/EPX3000

Output circuit type	Class H
---------------------	---------

### POWER SUPPLY / VOLTAGE (FUSES)

#### EPX2000

USA / Canada	120 V~, 60 Hz (T 20 A H 250 V)
--------------	-----------------------------------

UK / Australia	240 V~, 50 Hz (T 10 A H 250 V)
----------------	-----------------------------------

Europe	230 V~, 50 Hz (T 10 A H 250 V)
--------	-----------------------------------

Japan	100 V~, 50-60 Hz (T 20 A H 250 V)
-------	--------------------------------------

Power consumption	3000 W
-------------------	--------

Mains connector	Standard IEC receptacle
-----------------	-------------------------

#### EPX3000

USA / Canada	120 V~, 60 Hz (T 30 A H 250 V)
--------------	-----------------------------------

UK / Australia	240 V~, 50 Hz (T 15 A H 250 V)
----------------	-----------------------------------

Europe	230 V~, 50 Hz (T 15 A H 250 V)
--------	-----------------------------------

Japan	100 V~, 50-60 Hz (T 30 A H 250 V)
-------	--------------------------------------

Power consumption	4500 W
-------------------	--------

Mains connector	Standard IEC receptacle
-----------------	-------------------------

### DIMENSIONS/WEIGHT

Dimensions (H x W x D)

Weight

BEHRINGER is constantly striving to maintain the highest professional standards. As a result of these efforts, modifications may be made from time to time to existing products without prior notice. Specifications and appearance may differ from those listed or illustrated.

For service, support or more information contact the BEHRINGER location nearest you:

**Europe** Tel.: +49 2154 9206 4149, Fax: +49 2154 9206 4199  
**USA/Canada** Tel.: 1 425 672 0816, Fax: +1 425 673 7647  
**Singapore** Tel.: +65 5845 1800, Fax: +65 6214 0275

**Australia** Tel.: +61 3 9877 7170, Fax: +61 3 9877 7870  
**Japan** Tel.: +81 3 5281 1180, Fax: +81 3 5281 1181



©2010 Red Chip Company Ltd. Technical specifications and appearance subject to change without notice. The information contained herein is correct at the time of printing. All trademarks (except BEHRINGER, the BEHRINGER logo, EUROPOWER and EUROLIVE) mentioned belong to their respective owners, and such use neither constitutes a claim of the trademarks by Behringer nor affiliation of the trademark owners with Behringer. BEHRINGER accepts no liability for any loss which may be suffered by any person who relies either wholly or in part upon any description, photograph or statement contained herein. 985-10000-00408

**behringer.com**