

programm

performance sequencer

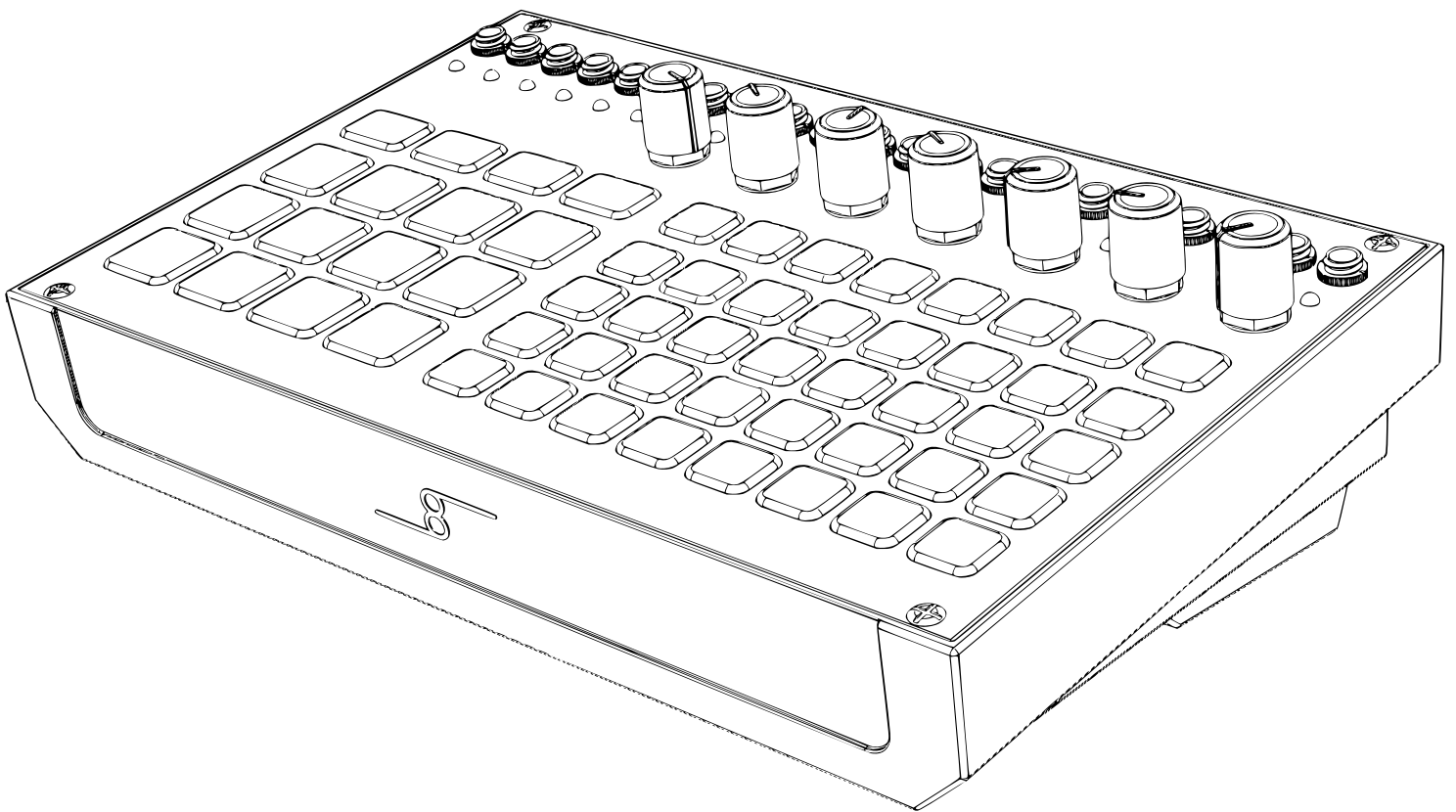

User Manual v1.0



cre8audio™

Acknowledgements

Product Design :	Richard Nicol
Firmware and Manual :	Luna Sea Peaks
Analog Research and Engineering :	Michael Johnsen
Sound Refinement and Calibration :	Perry Willig
Prototyping :	Ross Johnson
Executive Producer :	Al Joelson
Layout and Design :	Jongjian Cai
Firmware Support :	Zhiwen Huang
Project Logistics :	Alice Lai
Business Coordination :	Danielle Nicol



Table of Contents

01 Important Power Information	6	09 Drum Channels	16
01.01 : Read Instructions!		09.01 : Drum Channels	
01.02 : Eurorack Power Cable Information		09.02 : Drum Channel Midi Note #	
		09.03 : Drum Channel Knobs	
02 Overview	7	09.04 : Drum Step Knobs	
02.01 : Overview		09.05 : Drum Variation Settings	
02.02 : Manual Conventions			
03 User Interface	8	10 Seq.x Channels	18
03.01 : UI Elements		10.01 : Seq.x Channels	
03.02 : UI Basics		10.02 : Seq.x Channel Voice Modes	
		10.03 : Seq.x Step Knobs	
04 Sequencer Overview	10	10.04 : Seq.x Channel Outputs	
04.01 : Sequencer Core		10.05 : Key and Scale	
04.02 : Play and Stop			
04.03 : Drum Channels vs Seq.x Channels		11 Voice Modes: Mono Mode	20
		11.01 : Mono Mode Overview	
05 The Clock	11	11.02 : Mono Mode Channel Knobs	
05.01 : The Clock		11.03 : Mono Mode Variation Settings	
05.02 : Clock Source			
05.03 : Internal Clock Tempo		12 Voice Modes: Arp Mode	21
05.04 : External Clock Mode		12.01 : Arp Mode Overview	
05.05 : MIDI Clock Mode		12.02 : Arp Mode Channel Knobs	
05.06 : Output Multiplication		12.03 : Arp Mode Channel Variation Settings	
05.07 : Input Division			
05.08 : MIDI PPQ		13 Voice Modes: Chord Mode	22
		13.01 : Chord Mode Overview	
06 Step Mode	13	13.02 : Chord Voicing	
06.01 : Step Mode Overview		13.03 : Chord Mode Channel Knobs	
06.02 : Sequencing in Step Mode		13.04 : Chord Mode Variation Settings	
06.03 : Page			
07 Live Mode	14	14 Voice Modes: Chip Mode	24
07.01 : Live Mode Overview		14.01 : Chip Mode Overview	
07.02 : Drum Pads		14.02 : Chip Mode Channel Knobs	
07.03 : Live Keyboard		14.03 : Chip Mode Channel Variation Settings	
07.04 : Live Mode Record			
07.05 : Live Mode Recall		15 Mono/Arp Mode Keyboards	25
		15.01 : Mono/Arp Mode Keyboard Layouts	
08 Setting Knobs	15	15.02 : Chromatic Keyboard Layout	
08.01 : Setting Knobs		15.03 : Major Keyboard Layout	
08.02 : Channel Settings		15.04 : Minor Keyboard Layout	
08.03 : Step Settings		15.05 : Whole-Tone Keyboard Layout	
		15.06 : Pentatonic Keyboard Layout	

Table of Contents

16 Chord/Chip Mode Keyboards	27	24 Chance Input	38
16.01 : Chord/Chip Mode Keyboard Layouts		24.01 : Chance Input	
16.02 : Chromatic Chord Layout		24.02 : Chance In Amount	
16.03 : Major Chord Layout			
16.04 : Minor Chord Layout			
16.05 : Whole-Tone Chord Layout			
16.06 : Pentatonic Chord Layout			
17 Octave	29	25 MIDI Settings	39
17.01 : Octave Offsets		25.01 : The MIDI Screen	
		25.02 : MIDI Channel	
		25.03 : MIDI Cc Channel	
		25.04 : MIDI Thru	
18 Mutes	30	26 Using External MIDI Controllers	40
18.01 : Mutes		26.01 : MIDI to CV Conversion	
18.02 : Channel Mutes		26.02 : MIDI Controlling Drum Channels	
18.03 : Mute All		26.03 : MIDI Controlling Seq.x Channels	
		26.04 : MIDI TRS Type A	
19 Hold and Transpose	31	27 Saving and Loading Sequences	41
19.01 : Hold		27.01 : Save Slots	
19.02 : Transpose		27.02 : Saving Sequences	
		27.03 : Loading Sequences	
		27.04 : Clearing Save Slots	
		27.05 : Load Startup	
20 Division, Direction, and Quantize	32	28 Clear Tool	42
20.01 : Clock Division		28.01 : Clear Tool	
20.02 : Direction		28.02 : Everything you can Clear	
20.03 : Quantize			
21 Groove	33	29 Copy Tool	48
21.01 : What is Groove?		29.01 : Copy Tool	
21.02 : The Groove Counter		29.02 : Copy a Drum Channel	
21.03 : The Six Groove Algorithms for Drums		29.03 : Copy a Seq.x Channel	
21.04 : The Six Groove Algorithms for Seq.x Channels		29.04 : Copy a Step	
22 Pattern Generator	35	30 Song Mode	49
22.01 : The Pattern Generator		30.01 : Song Mode	
22.02 : Generator Algorithms		30.02 : Song Load Screen	
22.03 : Generate Behaviors		30.03 : What is a Song?	
22.04 : Generator Drum Map		30.04 : Building a Song	
22.05 : Generating Fills		30.05 : Clearing a Song Step	
		30.06 : Saving a Song	
		30.07 : Play a Song	
		30.08 : Song Corruption	
23 Length and Extend	37		
23.01 : Changing Sequence Length			
23.02 : The Length Tool			
23.03 : the Extend Tool			

Table of Contents

31 | Clock and Reset Jacks 51

- 31.01 : Clock and Reset Input Electrical Characteristics
- 31.02 : Reset Input
- 31.03 : Clock Input
- 31.04 : Reset Output
- 31.05 : Clock Output

32 | Screen Legend 52

- 32.01 : Numbers and Special Characters
- 32.02 : Letters Aa-Rr
- 32.03 : Letters Ss - Zz, Groove Modes, No/Off Screen
- 32.04 : Trig Conditions
- 32.05 : Edit Screens
- 32.06 : Arp Octaves
- 32.07 : Arp Directions, Seq. Directions, Clock Sources
- 32.08 : Generator Algorithms and Chord Voicings
- 32.09 : Voice Modes and Scales

33 | Factory Reset 61

- 33.01 : Digital Settings Reset
- 33.02 : Full Factory Reset

34 | Firmware 62

- 34.01 : Firmware Revision Screen
- 34.02 : Firmware Updates

35 | Warranty and Service 63

- 35.01 : Warranty
- 35.02 : Service and Contact Information

01 | Important Power Information

01.01 Read Instructions!

Please read the Cre8audio Programm Sequencer User Guide completely before use and retain for future reference.

- Only use the DC power adapter provided by Cre8audio with the Programm Sequencer. Using an incorrect power adapter can cause permanent damage to the Programm Sequencer and the power adapter.
- The Programm Sequencer is an electronic device. Exposure to water will cause the Programm Sequencer circuitry to short circuit and may cause permanent damage.
- Do not attempt to modify the Programm Sequencer. Tampering with the circuitry may cause permanent damage.
- Do not place heavy objects on the Programm Sequencer. The user interface is mounted on a PCB that can be damaged if stressed by excessive weight.
- Do not attempt to repair the Programm Sequencer. Please contact Cre8audio regarding malfunctions of any kind.
- Cre8audio is not responsible for any damage or loss caused by improper use of the Programm Sequencer.

01.02 Eurorack Power Cable Information

The Cre8audio Programm Sequencer is a Eurorack format synthesizer module. The module can be installed, rearranged, removed, and replaced in any compatible Eurorack case.

The Cre8audio Programm Sequencer uses a standard 16 pin Eurorack ribbon cable to connect the module to a bipolar +/-12v power supply. Please pay very close attention to the orientation of the ribbon cable when adding and removing modules. The stripe on the ribbon cable marks -12 volt power. This stripe needs to line up with the -12 volt pins on the power supply and the -12 volt pins on the module. The Cre8audio Programm Sequencer includes reverse polarity protection so it will not be damaged when plugged in incorrectly; however, as a general rule, failure to match up the pins correctly can result in damage to one or all the modules in a case. On Cre8audio and Pittsburgh Modular cases the positive and negative voltages are clearly labeled. On the Cre8audio Programm Sequencer module, the power header is clearly labeled and keyed to ensure a safe and proper connection.

Do NOT remove the Cre8audio Programm Sequencer module from any case while it is plugged in.

Do NOT unplug power ribbon cables from the Cre8audio Programm Sequencer or case while the case is plugged in.

02 | Overview

02.01 Overview

The Cre8audio Programm is a compact, powerful performance sequencer designed to be the brain of any setup.

Programm combines consistent, intuitive workflow with a modern featureset and a host of experimental generative tools to bring musicians a quick, performative music-making experience.

With Programm, you can sequence eight mono drum tracks and four synth tracks in monophonic and polyphonic modes using Midi or CV, with access to all the settings and features that modern synth music demands.

02.02 Manual Conventions

There are a couple of conventions to know while navigating this manual, to make things easy:

- Jacks are referenced in **bold**, inside curly braces eg: **{Drum 1 Output}**
- Buttons and knobs are referenced in **bold**, inside brackets eg: **[Pitch Knob]**
- Alt. Functions of buttons and knobs are referenced in **Orange** eg: **[Hold Button]**
(Use Alt. Functions by holding the **[(alt.) Button]** + the knob or button)
- Feature names and key terms that are explained elsewhere in the text are shown in **bold**.
- LEDs are referenced in **bold**, inside parentheses, eg: **(Drum 1 Gate LED)**

03 | User Interface

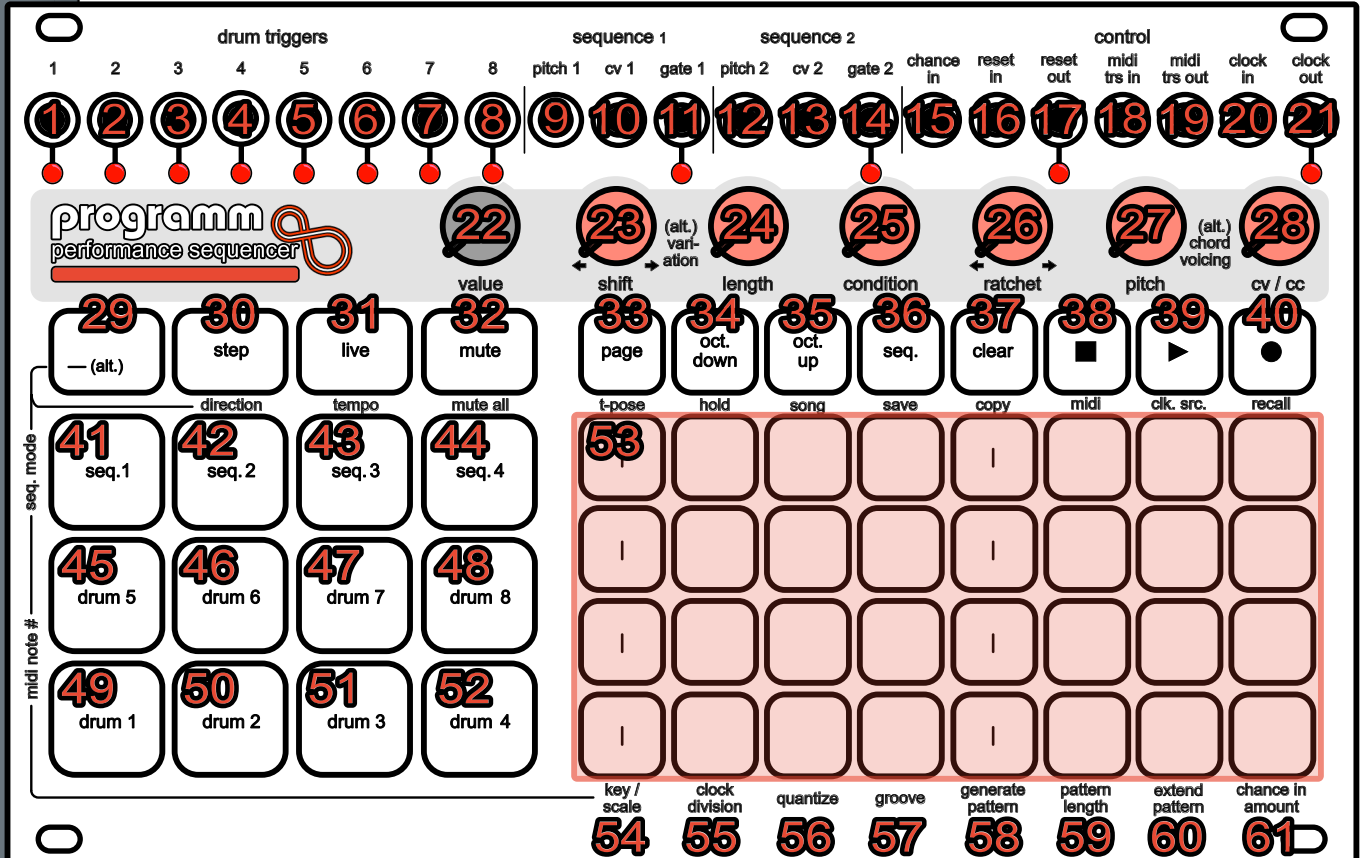

03.01 - UI Elements

- | | | |
|--------------------------|-------------------------------|---------------------------------------|
| 1 - Drum 1 Output | 22 - Value Knob | 43 - Seq.3(Seq.3 Mode) Button |
| 2 - Drum 2 Output | 23 - Shift Knob | 44 - Seq.4(Seq.4 Mode) Button |
| 3 - Drum 3 Output | 24 - Length Knob | 45 - Drum 5(Drum 5 Midi#) Button |
| 4 - Drum 4 Output | 25 - Condition Knob | 46 - Drum 6(Drum 6 Midi#) Button |
| 5 - Drum 5 Output | 26 - Ratchet Knob | 47 - Drum 7(Drum 7 Midi #) Button |
| 6 - Drum 6 Output | 27 - Pitch Knob | 48 - Drum 8(Drum 8 Midi#) Button |
| 7 - Drum 7 Output | 28 - CV/CC Knob | 49 - Drum 1(Drum 1 Midi#) Button |
| 8 - Drum 8 Output | 29 - (alt.) Button | 50 - Drum 2(Drum 2 Midi#) Button |
| 9 - Seq. 1 Pitch Output | 30 - Step(Direction) Button | 51 - Drum 3(Drum 3 Midi#) Button |
| 10 - Seq. 1 CV Output | 31 - Live(Tempo) Button | 52 - Drum 4(Drum 4 Midi#) Button |
| 11 - Seq. 1 Gate Output | 32 - Mute(Mute All) Button | 53 - Step Grid Buttons |
| 12 - Seq. 2 Pitch Output | 33 - Page(T-Pose) Button | 54 - Step 25(Key/Scale) Button |
| 13 - Seq. 2 CV Output | 34 - Oct. Down(Hold) Button | 55 - Step 26(Clock Division) Button |
| 14 - Seq. 2 Gate Output | 35 - Oct. Up(Song) Button | 56 - Step 27(Quantize) Button |
| 15 - Chance Input | 36 - Seq(Save) Button | 57 - Step 28(Groove) Button |
| 16 - Reset Input | 37 - Clear(Copy) Button | 58 - Step 29(Generate Pattern) Button |
| 17 - Reset Output | 38 - Stop(Midi) Button | 59 - Step 30(Pattern Length) Button |
| 18 - Midi TRS Input | 39 - Play(Clk. Src.) Button | 60 - Step 31(Extend Pattern) Button |
| 19 - Midi TRS Output | 40 - Record(Recall) Button | 61 - Step 32(Chance Amount) Button |
| 20 - Clock Input | 41 - Seq.1(Seq.1 Mode) Button | |
| 21 - Clock Output | 42 - Seq.2(Seq.2 Mode) Button | |

03 | User Interface

03.02 - UI Basics

Channel Buttons

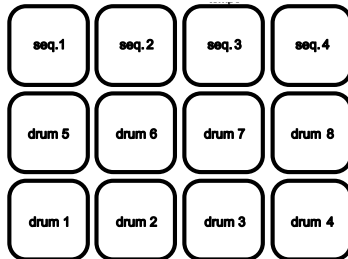

Programm's **Channel Buttons** are found on the bottom left of the device, and are used to select a channel in **Step Mode**. In **Live Mode**, use the **Seq.x Channel Buttons** to select a **Keyboard Channel**, or use the **Drum Channel Buttons** as drum pads.

Setting Knobs



Programm's **Setting Knobs** are used to set values throughout the Sequencer's UI. They can be used to set global **Channel Settings**, or to modify **Step Settings**, but in some **Edit Screens**, they modify the behaviors of a feature.

Step Mode and Live Mode



Programm has two main functional modes: **Step Mode** and **Live Mode**. Entering **Step Mode** or **Live Mode** is simple: use the [**Step Button**] to enter **Step Mode**, and use the [**Live Button**] to enter **Live Mode**. While in **Step Mode**, the (**Step Button LED**) will be lit. While in **Live Mode**, the (**Live Button LED**) will be lit.



In **Step Mode**, sequences can be edited per step by selecting a **Seq.x Channel** or **Drum Channel** and then using the [**Step Buttons**] and [**Setting Knobs**] to modify each step individually.



In **Live Mode**, the [**Drum Channel Buttons**] behave as Drum Pads and the [**Seq.x Channel Buttons**] are used to select the **Keyboard Channel**. While in **Live Mode**, the **Step Buttons** are used as a **Performance Grid Keyboard** to play notes on the **Seq.x Channels**.

Edit Screens



Using Programm's **Alt. Functions** will open **Edit Screens** which are used to modify an **Alt. Function's** settings. **Edit Screens** share a common set of UI sensibilities which will change slightly depending on the **Alt. Function** :

- Enter **Edit Screens** using the [(**Alt.**) Button] and pressing an [**Alt. Function Button**].
- Exit **Edit Screens** by using the [(**Alt.**) Button].
- While in an **Edit Screen**, use the [**Channel Buttons**] to select the channels you want to edit, and use the [**Settings Knobs**] or [**Step Buttons**] to use the **Edit Function**.
- Inside most **Edit Screens**, the (**Step Button LEDs**) will tell you which **Edit Screen** you are in.
- Some **Edit Screens** have **Secondary Settings**, accessed using the [**Alt. Function Button**] again while in the **Edit Screen**.

Some **Edit Screens** behave differently, this will be discussed in their relevant sections of the manual.

04 | Sequencer Overview

04.01 - Sequencer Core

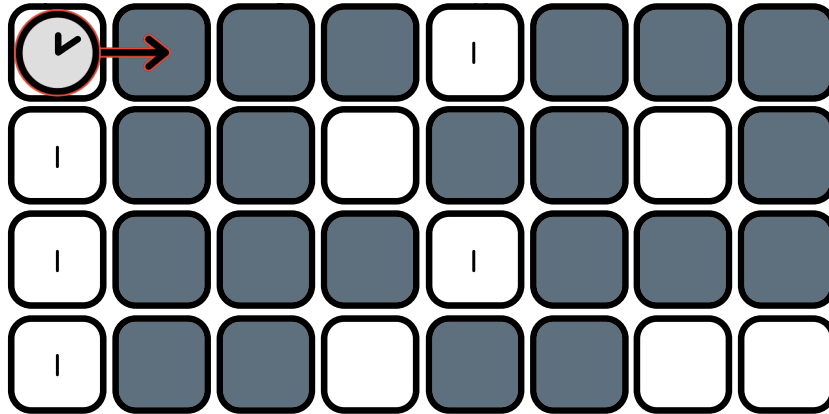

Programm is a step sequencer with up to 64 steps. The **Clock** moves through each **Step** of a sequence and plays the **Step** as it arrives at that **Step**. Each **Step** has a bunch of **Step Values**, set with the **Setting Knobs**, that change how that **Step** behaves when the **Sequencer** plays it.

04.02 - Play and Stop



Start the **Sequencer** with the **[Play Button]** and Stop with the **[Stop Button]**.

The **Sequencer** will also respond to **MIDI Clock Start** and **MIDI Clock Stop** messages in **MIDI Clock Mode**.

04.03 - Drum Channels vs Seq.x Channels



Programm has two types of **Channels**: eight **Drum Channels** and four **Seq.x Channels**.

Drum Channels generate gates sent over **MIDI** and out the **{Drum X Outputs}**.

Seq.x Channels generate gates, pitches, and CV values, sent using **MIDI Note On Messages** and the **{Seq.x Outputs}**, for sequencing pitched synth voices.

05 | The Clock

05.01 - The Clock

Programm has a core **Clock** that triggers the **Sequencer** to progress through steps. The **Clock** sets the tempo of Programm, and can be controlled by an **Internal Clock**, **External Clock**, or **MIDI Clock**. The **Clock** will trigger **Clock Ticks** based on its **Clock Source**, progressing the **Sequencer**.

05.02 - Clock Source



You can set the **Clock Source** to **Internal Clock**, **External Clock**, or **MIDI Clock** by using the **[Clk. Src. Button]** and then turning the **[Value Knob]** to select from the three available **Clock Sources**. **Clock Source** is a **Global Setting**, which means it applies to all of Programm's 12 **Channels**. In the **Clock Source Screen**, all the **(Channel Button LEDs)** will be lit to communicate this.

The **Clock Source Screen** is one of a few screens that has **Secondary Settings**. To access the **Secondary Setting**, use the **[Clk. Src. Button]** again while in the **Clock Source Screen** and the **(Step Grid LEDs)** will show the **Secondary Setting** being edited. The **Secondary Settings** for the **Clock Source Screen** are: **Clock Input Division**, **Clock Output Multiplication**, and **MIDI PPQ**.

05.03 - Internal Clock Tempo

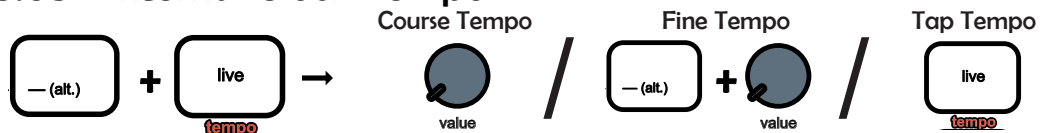

Using **Internal Clock**, the **Tempo** is set using the **Tempo Screen**. Enter the **Tempo Screen** using the **[Tempo Button]**.

While in the **Tempo Screen**, use the **[Value Knob]** alone to set the **Tempo** from 30 bpm to 300 bpm.

Use the **[Value Knob]** with the **[(Alt.) Button]** to fine adjust the **Tempo** by +/- 20 bpm.

Or tap in the **Tempo** using the **[Tempo Button]**.

Tempo is a **Global Setting**, which means it applies to all of Programm's 12 **Channels**. In the **Tempo Screen**, all the **(Channel Button LEDs)** will be lit to communicate this.

05.04 - External Clock Mode

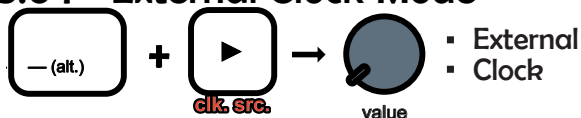

Using **External Clock**, the **Tempo** is set by an analog gate source sent into the **{Clock Input}**, based on the **Input Division** of the **Clock**.

When the **{Clock Input}**'s rate changes, the **Tempo** will adjust to follow it.

If the **Sequencer** is **Stopped**, receiving a gate on the **{Clock Input}** will start the **Sequencer**.

If a gate is not received on the **{Clock Input}**, the **Sequencer** will **Stop** itself and after eight step times, it will reset itself to step one.

05.05 - MIDI Clock Mode



Using **MIDI Clock**, the **Tempo** is set by **MIDI Clock Messages** sent into the **{MIDI TRS Input}**, based on the **MIDI PPQ** of the **Clock**.

The **MIDI Clock** will start and stop when receiving **MIDI Clock Start** and **MIDI Clock Stop** messages.

05 | The Clock

05.06 - Output Multiplication



Output Multiplication changes the rate at which the **{Clock Output}** sends gates, allowing Programm to interface with outboard gear that uses a different analog clock standard. There are five **Output Multiplication** modes: *1, *2, *4, *6, and *12. For example: in *12 mode, the **{Clock Output}** will send 12 gates for each **Clock Tick**.

Output Multiplication is a **Global Setting**, which means it applies to all of Programm's 12 **Channels**. In the **Clock Source Screen**, all the **(Channel Button LEDs)** will be lit to communicate this.

05.07 - Input Division



Input Division changes the number of incoming pulses on the **{Clock Input}** that the **External Clock** will use as one **Clock Tick**. This enables Programm to be clocked from external gear with faster clock standards.

The available **Input Divisions** are: /1, /2, /4, /6, and /12. For example: in /12 mode, the **{Clock Input}** will trigger a **Clock Tick** after receiving 12 external clock pulses.

05.08 - MIDI PPQ



MIDI PPQ changes the number of incoming **MIDI Clock Messages** to the **{MIDI TRS Input}** that the **MIDI Clock** will use as one **Clock Tick**. This enables Programm to be clocked from external gear with faster midi clock standards.

MIDI PPQ also changes the number of **MIDI Clock Messages** sent on the **{MIDI TRS Output}** every **Clock Tick**. This enables Programm to clock external gear with faster midi clock standards.

The available **MIDI PPQ** settings are: 6ppq and 24ppq. For example: in 24 ppq mode, the **{MIDI TRS Output}** will send 24 **MIDI Clock Messages** for every **Clock Tick**.

06 | Step Mode

06.01 - Step Mode Overview



In **Step Mode**, you can edit each of the 12 **Sequencer Channels** per step to dial in your sequences with full control.

06.02 - Sequencing in Step Mode

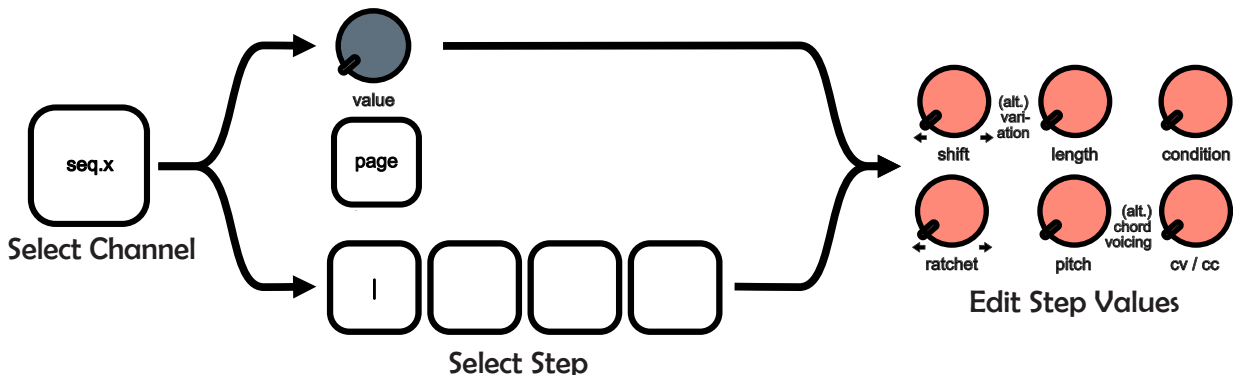

To create and edit **Sequences** in **Step Mode**, first select a **Sequencer Channel** using the [Channel Buttons] and the (Step Grid LEDs) will show the **Active Steps** for that **Sequencer Channel**.

After selecting a **Sequencer Channel**, the (Channel Button LED) for that **Channel** will be flashing. While the **Sequencer Channel** is flashing, use the **Orange** [Setting Knobs] to adjust the **Channel Settings**.

There are two ways to sequence steps in **Step Mode**: using just the [Setting Knobs] or using the [Step Grid Buttons].

Off = Step Off

On = Step On

Slow = Selected, Step Off

Fast = Selected, Step On

To dial in a **Sequence** using the [Step Grid Buttons], simply use the [Step Grid Buttons] to turn on and off **Steps**. After turning on or off a **Step**, you will notice that the **Step** will be flashing to indicate the currently selected **Step**. If the **Step** is flashing quickly, the step is on. If the step is flashing slowly, the **Step** is off.

To dial in a sequence using just the [Setting Knobs], use the [Value Knob] to select a **Step** to edit, and the selected **Step** will be flashing.

Using any of the six **Orange** [Setting Knobs] will change the **Step Settings** for the selected **Step**. Every **Step** has 12 settings corresponding to each knob: **Shift**, **Length**, **Condition**, **Ratchet**, **Pitch**, **CV/CC**, and a **Variation Value** for each of the six **Orange** [Setting Knobs]. These are discussed in the **Drum Channel** and **Seq.x Channel** sections.

Any time a **Step Value** is changed, the corresponding **Step** will turn on.

06.03 - Page



If a **Sequence** is longer than 32 steps, use the [Page Button] to view and edit the second page of the **Sequence**. The (Page Button LED) will be lit when viewing page 2, and off when viewing page 1.

07 | Live Mode

07.01 - Live Mode Overview



In **Live Mode**, you can play your **Channels** live and **Record** them to create **Sequences**.

While in **Live Mode**, the (**Step Button LEDs**) will show the **Live Keyboard** for your selected **Keyboard Channel**, which is displayed on the (**Seq.X Button LEDs**). The [**Drum x Buttons**] in **Live Mode** behave as playable **Drum Pads**.

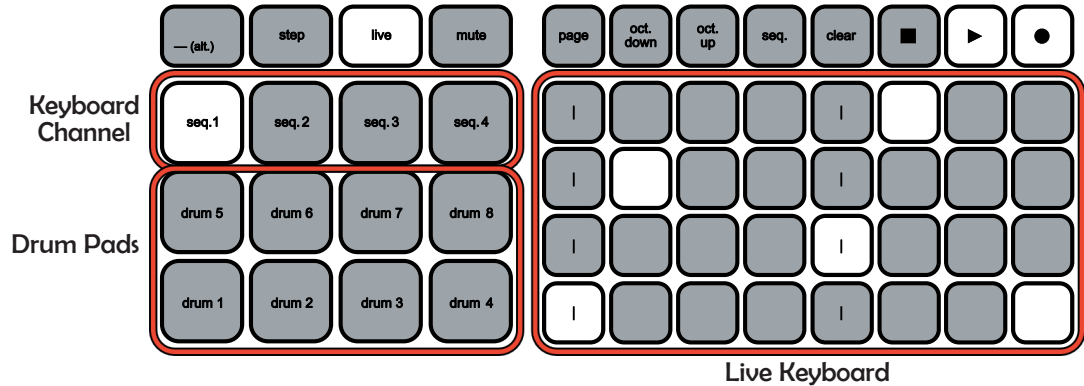

07.02 - Drum Pads

The **Live Mode Drum Pads** allow a user to send gates to the {**Drum Trigger Outputs**} and **MIDI Note On Messages** to the {**MIDI TRS Output**}.

07.03 - Live Keyboard

The **Live Keyboard** allows you to play notes on the **Seq.x Channels** using the [**Step Grid Buttons**]. The **Live Keyboard Layout** will change depending on the **Scale** and **Voice Mode** of your **Seq.x Channel**.

When a [**Step Grid Button**] is pressed in **Live Mode**, a note will be played on the selected **Keyboard Channel**. Use the [**Seq.x Buttons**] to select the **Keyboard Channel**.

All the **Live Keyboard Layouts** are explained later in this manual.

07.04 - Live Mode Record



To record in **Live Mode**, press the [**Record Button**] to arm recording. If notes are played with the **Live Keyboard** or the **Drum Pads** while **Play** and **Record** are both active, the notes played will be recorded by the **Sequencer**.

The **Record** function behaves with an overdub behavior, meaning new notes are added to the current / **Sequence** when played. If a note is recorded over top of an **Active Step**, it will over-write that **Step**.

07.05 - Live Mode Recall

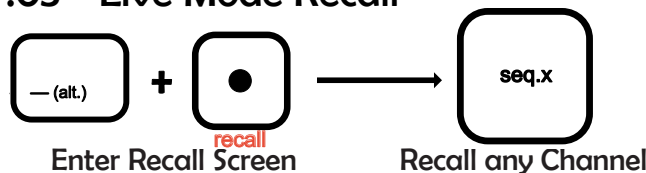

If you play something you like, but forgot to arm the **Record**, no problem! Simply use the [**Recall Button**] to enter the **Recall Screen**, and press any of the twelve [**Channel Buttons**] to **Recall** the last played loop for that **Channel**.

Be aware! Recall will over-write your previous Sequence, and cannot be reversed!

08 | Setting Knobs

08.01 - Settings Knobs



The seven [Setting Knobs] are the main way values are changed in all of Programm's screens. Outside any of the Edit Screens, they are used to set **Channel Settings** and **Step Settings** which control how a Sequence is played by Programm.

08.02 - Channel Settings

Channel Settings are the top-level settings for a Channel that dictate how the Sequencer behaves for that particular Channel. The available Channel Settings are different for Seq.x Channels and Drum Channels.

Broadly, there are 13 Channel Settings for each Channel:

- One Channel Setting (Voice Mode or Midi Note#) which is set by holding a [Channel Button] and turning [Value Knob].



- Six Channel Value Settings (Shift, Length, Condition, Ratchet, Pitch, and CV/CC) which are set by selecting a Channel with the [Channel Buttons] then using the six Orange [Setting Knobs].

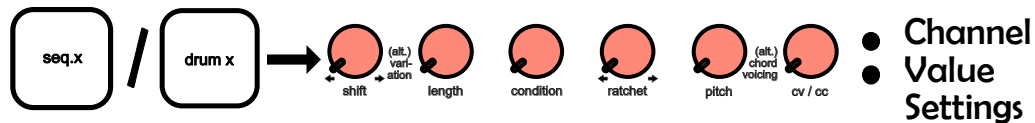

- Six Channel Variation Settings which are set by selecting a Channel with the [Channel Buttons] then using the [(Alt.) Button] with the Orange [Setting Knobs].

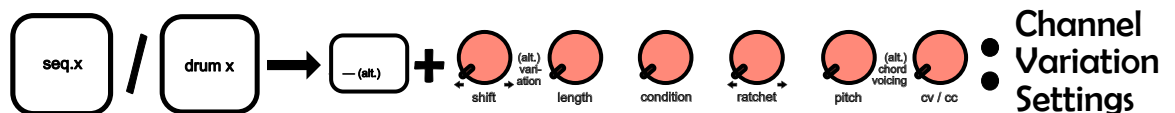

08.03 - Step Settings

Step Settings are settings that apply to an individual Step in a Sequence, and they dictate how that Step will behave when played. Step Settings behave differently for Seq.x Channels and Drum Channels.

Broadly, there are 12 Step Settings for each Step:

- Six Step Value Settings (Shift, Length, Condition, Ratchet, Pitch, and CV/CC) which are set by selecting a Step with either the [Step Grid Buttons] or the [Value Knob] then using the six Orange [Setting Knobs] to select a value.

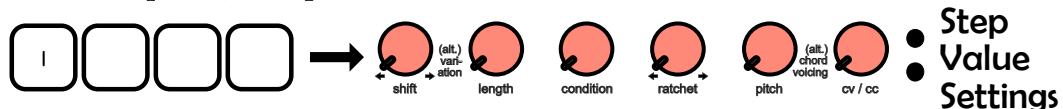

- Six Step Variation Settings which are set by selecting a Step with the [Step Grid Buttons] or the [Value Knob] then using the [(Alt.) Button] with the Orange [Setting Knobs] to select a value.

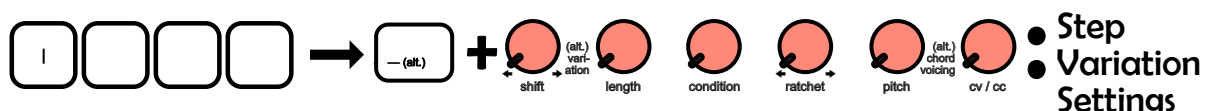

09 | Drum Channels

09.01 - Drum Channels

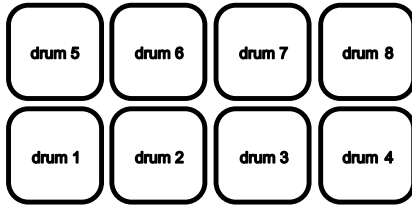

Programm has eight **Drum Channels** that can be used to sequence gates and short envelope MIDI signals for controlling drums and rhythmic patches.

09.02 - Drum Channel Midi Note

When a **Drum Channel** gate is triggered, a **MIDI Note On Message** is sent to the {TRS MIDI Output} using that **Drum Channel's** **Midi Note #**.

Programm has a default **MIDI Note # Map** that is based on the **General MIDI Drum Standard**, and common MPC Layouts:

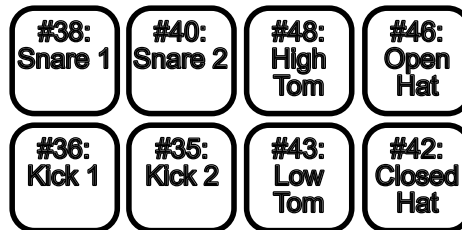





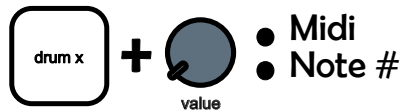

Note: This map is default compatible with **Boom Chick** and any **Pittsburgh Modular Drum Machines**.

This Map can be changed by holding a **[Drum Channel Button]** and using the **[Value Knob]**.



09.03 - Drum Channel Knobs

Programm's **Drum Channels** have six **Channel Value Settings**, one for each **Orange [Settings Knob]**:

-  - **Shift**: Moves all steps in the **Sequence** forward or backward in time by up to a half step.
-  - **Length**: Changes the default **Gate Length** of all **Steps** in a **Sequence** from 10ms to 200ms.
-  - **Condition**: Changes which repeats the **Sequence** will play on (eg: the first of four repeats)
-  - **Ratchet**: Changes the **Roll Step Length**, which is the number of **Steps** over which **Rolls** will be played.
-  - **Pitch**: Sets the **Alternate Midi Note#** for the **Drum Channel**.
-  - **CV/CC**: Sets the default **Midi CC Value** for the **Drum Channel**.

09 | Drum Channels

09.04 - Drum Step Knobs

Programm's **Dum Channel Steps** have six **Step Value Settings**, one for each **Orange [Settings Knob]**:



- **Shift**: Moves a **Step** forward or backward in time by up to a half step.



- **Length**: Changes the **Gate Length** of a **Step** from 10 ms to 200 ms, set to zero to use the default **Gate Length**.



- **Condition**: Changes which repeats the **Step** will play on(eg: the first of four repeats)



- **Ratchet**: Changes the **Ratchet** for a **Step**; making the step play a **Flam**(left) or **Roll**(right).



- **Pitch**: Selects whether the **Step** will use the **Drum Channel's MIDI Note #** or the **Alternate MIDI Note #** when sending the **MIDI Note On Message**.



- **CV/CC**: Sets the **Drum Accent** for the **Step**, which changes the **MIDI CC Value** used when sending the **MIDI Note On Message** by: -40, +0, +40, or +80.

09.05 - Drum Variation Settings

Programm's **Drum Channels** use **Variation** to randomize parameters when triggering **Drum Steps**. **Variation** uses the **Channel Variation Setting** as the **Default**, and the **Step Variation Setting** as the **Override**: if a **Step Variation Setting** is not set, the **Global Variation Setting** will be used.



- **Shift Variation**: Moves a **Step** forward or backward in time by a random amount, up to the **Shift Variation** level set.



- **Length Variation**: Randomizes the **Gate Length** of a **Step** based on the **Length Variation**.



- **Condition Variation**: Randomly skips triggering a **Step**; applies a percentage chance of skipping a **Step**.



- **Ratchet Variation**: Randomizes the **Ratchet** for a **Step**.



- **Pitch Variation**: Randomizes whether the **Step** will use the **Drum Channel's MIDI Note #** or the **Alternate MIDI Note #** when sending the **MIDI Note On Message**.



- **CV/CC Variation**: Randomly applies an offset to the Drum's **MIDI CC Value** when triggering the **MIDI Note On Message**.

Note: All of these **Variation Tools** are super opinionated, and we've made choices to keep them musical. Any percentages you see are meant to communicate a vibe, not necessarily an honest representation of the math.

10 | Seq.x Channels

10.01 - Seq.x Channels



Programm has four **Seq.x Channels** that can be used to sequence pitched synths. All four channels are able to sequence over **MIDI**, but channels **Seq.1** and **Seq.2** have **Pitch, CV, and Gate Outputs** for use with Eurorack and other analog systems.

10.02 - Seq.x Channel Voice Modes









Seq.x Channels each have four **Voice Modes**, selected by holding a **[Seq.x Button]** and using the **[Value Knob]**. The default **Voice Mode** is **Monophonic Mode**. **Voice Modes** change how the **Sequencer** and **Live Keyboard** work, enabling users to create and record **Arpeggiators, Chords, and Monophonic Sequences**. The four **Voice Modes** are:

- **Mono Mode** : The **Sequencer** is **Monophonic** and the **Live Keyboard** is a grid piano layout that can be played **Polyphonically**, but the record function records a **Monophonic Sequence**.
- **Arp Mode** : The **Sequencer** behaves exactly the same as in **Mono Mode**, but the **Live Keyboard** behaves as an **Arpeggiator**, where the notes held down are the arpeggiated notes.
- **Chord Mode** : The **Sequencer** plays chords over **MIDI**, and plays the root note with the **{Seq. Outputs}**. The **Live Keyboard** is a **Chord Keyboard** layout.
- **Chip Mode** : The **Sequencer** and **Live Keyboard** both work like in **Chord Mode** but the **{Seq. Outputs}** and **MIDI Messages** play the notes of the chord as an **Arpeggiator**.

The **Voice Mode** of a **Seq.x Channel** changes a lot about how that **Channel works**, including **Channel Knob Settings, Live Keyboard**, and how notes are played. That said, changing between **Voice Modes** is non-destructive, and preserves the underlying **Sequence** to play in any **Voice Mode**.

10.03 - Seq.x Step Knobs

Programm's **Seq.x Channel Steps** have six **Step Value Settings**, one for each **Orange [Settings Knob]**. **Step Value Settings** are the same in all **Voice Modes**:

-  - **Shift** : Shifts a **Step** in the **Sequence** forward or backward in time by up to a half step.
-  - **Length** : Changes the **Gate Length** of a **Step**.
-  - **Condition** : Changes which repeats the **Step** will play on(eg: the first of four repeats)
-  - **Ratchet** : Changes the **Ratchet** for a **Step**; making the step play a **Flam**(left) or **Roll**(right)
-  - **Pitch** : Sets the **Pitch** of the **Step**, selecting from notes in the chosen **Key and Scale**.
-  - **CV/CC**: Sets the **CV/CC** value for the **Step**.

10 | Seq.x Channels

10.04 - Seq.x Channel Outputs

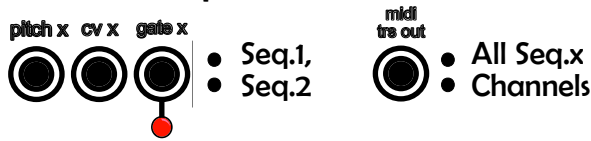

Programm's Seq.x Channels can generate **Analog Control Voltages** and **MIDI Messages** for controlling external synths. Seq.1 and Seq.2 generate both, while Seq.3 and Seq.4 only generate **MIDI Messages**.

midi trs out
 - The **{MIDI TRS Output}** sends **MIDI Signals** out from Programm, and the **Synth Channels** can generate **MIDI Note On** and **MIDI Note Off Messages** using the **{MIDI TRS Output}** to sequence any external gear with a **MIDI Input**.

pitch x
 - The **{Pitch Outputs}** generate a volt-per-octave quantized **Control Voltage** from 0-10 volts which can be used for controlling the pitch of oscillators and other modules with **Pitch Inputs**.

cv x
 - The **{CV Outputs}** generate an unquantized **Control Voltage** from 0-5 volts which can be used for modulating any module's **CV Inputs**.

gate x
 - The **{Gate Outputs}** generate 5 volt analog **Gate Signals** which can be used for triggering envelopes, slope generators, or any other module with **Gate Inputs**.

10.05 - Key and Scale

Programm's four **Seq.x Channels** can be pitch quantized to a chosen **Key** and **Scale** using the **Key/Scale Screen**. **Key** is a **Global Value**, and is applied to all **Seq.x Channels**, but **Seq.x Channels** can have different **Scales**.

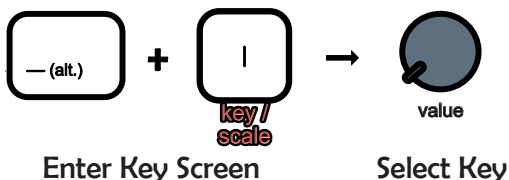

To select the **Key**, use the **[Key/Scale Button]** to enter the **Key Screen**, then use the **[Value Knob]** to select a **Key** for all **Seq.x Channels**.

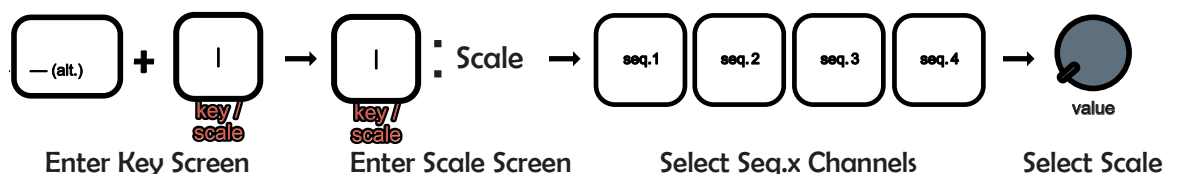

To select the **Scale**, use the **[Key/Scale Button]** to enter the **Key Screen**, then use the **[Key/Scale Button]** again to enter the **Scale Screen**, then use the **[Seq.x Buttons]** to select **Seq.x Channels** and use the **[Value Knob]** to select a **Scale** for those **Seq.x Channels**. Programm has five **Scales**: Chromatic, Major, Minor, Whole Tone, and Pentatonic.

11 | Voice Modes : Mono Mode



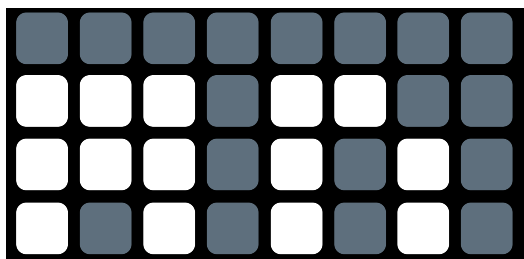



11.01 - Mono Mode Overview



Mono Mode is the default **Voice Mode** for all the **Seq.x Channels**. In **Mono Mode**, the **Sequencer** has one active note at a time.







11.02 - Mono Mode Channel Knobs

Programm's **Seq.x Channels** have six **Channel Value Settings** for each **Voice Mode**, one for each **Orange [Setting Knob]**. In **Mono Mode**, they are:

-  - **Shift**: Shifts every **Step** in the **Sequence** forward or backward in time by up to a half step.
-  - **Length**: Changes the maximum **Gate Length** for the Channel(4, 8, 12, or 16 steps).
-  - **Condition**: Changes which repeats the **Sequence** will play on(eg: the first of four repeats)
-  - **Ratchet**: Changes the **Ratchet Gate Length**, making the individual ratchets gates longer or shorter from 0% to 100%
-  - **Pitch**: Diatonically transposes the whole **Sequence** up or down by up to +/-12 semitones.
-  - **CV/CC**: Sets the default **CV/CC** value for the **Synth Channel**.

11.03 - Mono Mode Variation Settings

Programm's **Seq.x Channels** use **Variation** to randomize parameters when triggering **Steps**. **Variation** uses the **Channel Variation Setting** as the **Default**, and the **Step Variation Setting** as the **Override**: if a **Step Variation Setting** is not set, the **Global Variation** Setting will be used.

-  - **Shift Variation**: Moves a **Step** forward or backward in time by a random amount, up to the **Shift Variation** level set.
-  - **Length Variation**: Randomizes the **Gate Length** of a **Step** based on the **Length Variation**.
-  - **Condition Variation**: Applies a percentage chance of skipping a **Step**.
-  - **Ratchet Variation**: Randomizes the **Ratchet** for a **Step**, based on the chance shown.
-  - **Pitch Variation**: Randomizes the **Pitch** of a **Step**; in lower percentages you will get well tempered intervals, and in higher ranges odd-tempered intervals.
-  - **CV/CC Variation**: Randomly applies an offset to the **Step's MIDI CC Value** when triggering the **MIDI Note On Message**, and applies the same offset to the **{CV Output}**.

Note: All of these **Variation Tools** are super opinionated, and we've made choices to keep them musical. Any percentages you see are meant to communicate a vibe, not necessarily an honest representation of the math.

12 | Voice Modes : Arp Mode

12.01 - Arp Mode Overview

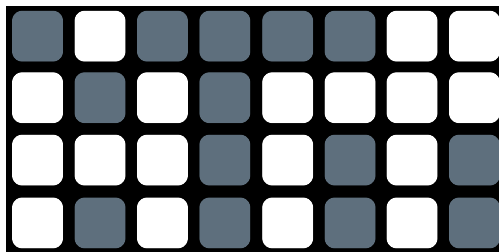







In **Arp Mode**, the **Sequencer** behaves exactly the same as in **Mono Mode**, and **Step Mode** is identical to as in **Mono Mode**. However, in **Arp Mode** the **Live Keyboard** will drive an **Arpeggiator**. The **Arpeggiator** in **Arp Mode** can be recorded into the **Sequencer** and then modified as a mono sequence, making it a useful tool for creating fast melodies.

The **Live Keyboard Layouts** in **Arp Mode** are exactly the same as in **Mono Mode**!







12.02 - Arp Mode Channel Knobs

Programm's **Seq.x Channels** have six **Channel Value Settings** for each **Voice Mode**, one for each **Orange [Settings Knob]**. In **Arp Mode**, they are:

-  - **Shift**: Selects the **Arp Direction** for the **Arpeggiator**: Up, Down, Order, Random, Stochastic Random (doesn't reshuffle on repeats), up/down inclusive (repeats the top and bottom notes), up/down exclusive (doesn't repeat the top and bottom note), up 2 down 1, down/up inclusive, down/up exclusive, and down 2 up 1.
-  - **Length**: Changes the **Arpeggiator Gate Length**, the percentage of the **Arp Step** that the **Gate** will stay on from 1 to 100%.
-  - **Condition**: Applies an **Arp Condition Counter**, so that steps will sometimes skip (eg play the 1st and 3rd of every four **Arp Steps**).
-  - **Ratchet**: Selects from the 16 available **Arpeggiator Clock Multiplications/Divisions** (**Arp clocks / Sequencer Clocks**): 1/1, 7/8, 6/7, 5/6, 4/5, 3/4, 2/3, 1/2, 3/7, 2/5, 3/8, 1/3, 2/7, 1/4, 1/5, and 1/6.
-  - **Pitch**: Selects from the 16 available **Arp Octave** settings: off, up 1, up 2, up 3, down 1, down 2, down 3, 25% random, 50% random, 75% random, 90% random, up 1>down 1, up/down 1, up/down 2, up/down 3, up/down 4, and up/down random.
-  - **CV/CC**: Sets the **Arpeggiator CV/CC Amount**, which increases or reduces the **CC/CV** value of each note in the **Arp** based on how far from the first note the **Arp Step** is.

12.03 - Arp Mode Channel Variation Settings

The **Channel Variation Settings** are different to the **Step Variation Settings** in **Arp Mode**. The **Channel Variation Settings** are:

-  - **Shift Variation**: Randomly makes the **Arpeggiator** increment in the wrong direction or repeat an **Arp Step**.
-  - **Length Variation**: Randomizes the **Gate Length** of an **Arp Step** based on the **Length Variation** set.
-  - **Condition Variation**: Randomly skips triggering an **Arp Step**, applies a percentage chance of skipping an **Arp Step**.
-  - **Ratchet Variation**: Randomizes the **Arpeggiator Clock Multiplications/Divisions** every time the **Arpeggiator** resets.
-  - **Pitch Variation**: Randomizes the pitch of each **Arp Step**: in lower percentages you will get well tempered pitches, and in higher ranges odd-tempered intervals.
-  - **CV/CC Variation**: Randomly applies an offset to the **Arp Step's CC Value** when triggering the **MIDI Note On Message**, and applies the same offset to the **{CV Output}**.

13 | Voice Modes : Chord Mode

13.01 - Chord Mode Overview

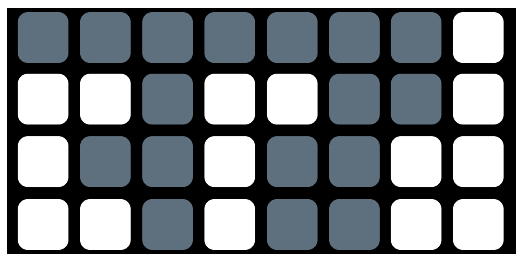

Chord Mode allows a user to **Sequence Chords** using MIDI.

Sequencing in **Chord Mode** is very similar to **Mono Mode**, except the **Step Pitch Variation** is replaced by **Chord Voicing**, and **Channel Settings** are very different.

The **Live Keyboard Layouts** are also different in **Chord Mode**.

13.02 - Chord Voicing

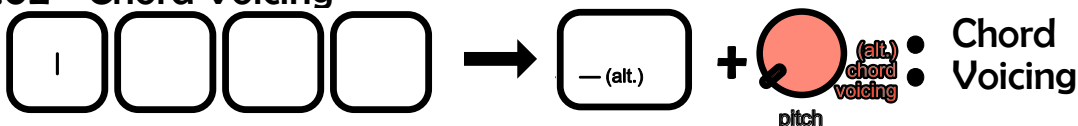

There are 16 available **Chord Voicings** in Programm's **Chord Mode**. When sequencing **Steps**, first use the **[Pitch Knob]** to set the **Chord's Root Note**, then use **[(alt.) Chord Voicing]** to assign one of the 16 **Chord Voicings** to the **Step**.

Major Chords (Voicings 1-8)

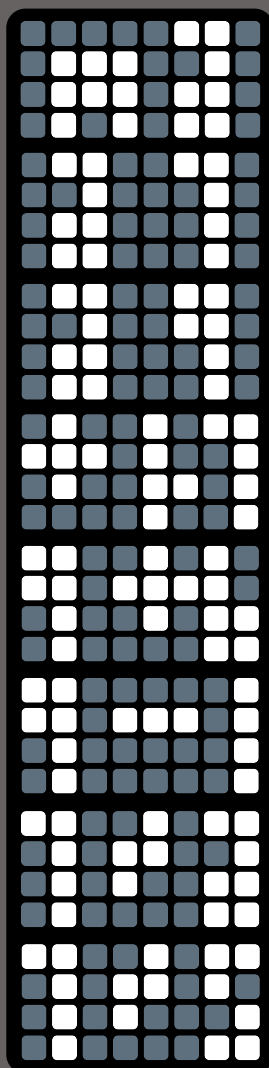

Major Triad
(1,3,5)

Major Seven
(1,3,5,7)

Major Nine
(1,3,5,7,9)

Major, Flat 7
(1,3,5, b 7)

Major Nine Six
(1,3,6,9)

Major 9, Rootless
(3,5,7,9)

Major 7, sharp 3
(1, \sharp 3,5,7)

Major 7, sharp 5
(1,3, \sharp 5,7)

Minor Chords (Voicings 9-16)

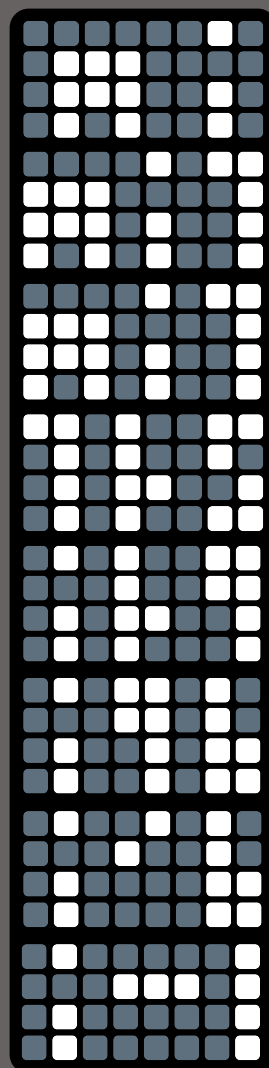

Minor Triad
(1,i3,5)

Minor Seven
(1,i3,5,7)

Minor Nine
(1,i3,5,7,9)

Minor Seven, dim. 5
(1,i3, b 5,7)

Minor dim. 9
(1,i3,5,7, b 9)

Minor Nine Six
(1,i3,i6,9)







Minor 9, Sharp Six
(1,i3, α 6,9)

Minor 9, Rootless
(i3,5,7,9)

13 | Voice Modes : Chord Mode







13.03 - Chord Mode Channel Knobs

Programm's Seq.x Channels have six **Channel Value Settings** for each **Voice Mode**, one for each **Orange [Setting Knob]**. In **Chord Mode**, they are:

-  - **Shift**: Shifts every **Step** in the **Sequence** forward or backward in time by up to a half step.
shift
-  - **Length**: Changes the maximum **Gate Length** for the **Channel**(4, 8, 12, or 16 steps).
length
-  - **Condition**: Changes which repeats the **Sequence** will play on(eg: the first of four repeats)
condition
-  - **Ratchet**: Changes the **Ratchet Gate Length**, making the individual ratchets gates longer or shorter from 0% to 100%
ratchet
-  - **Pitch**: Changes the **Note Count** of the **Chord** from 1-16 notes.
pitch
-  - **CV/CC**: Sets the default **CV/CC** value for the **Synth Channel**.
cv / cc

13.04 - Chord Mode Variation Settings

Programm's Seq.x Channels use **Variation** to randomize parameters when triggering **Steps**. **Variation** uses the **Channel Variation Setting** as the **Default**, and the **Step Variation Setting** as the **Override**: if a **Step Variation Setting** is not set, the **Global Variation** Setting will be used.

-  - **Shift Variation**: Moves a **Step** forward or backward in time by a random amount, up to **Shift Variation** level set.
shift
-  - **Length Variation**: Randomizes the **Gate Length** of a **Step** based on the **Length Variation**.
length
-  - **Condition Variation**: Applies a percentage chance of skipping a **Step**.
condition
-  - **Ratchet Variation**: Randomizes the **Ratchet** for a **Step**, based on the chance shown.
ratchet
-  - **Pitch Variation**: Randomizes the **Chord Voicing** of a **Step**(Global Only).
Note! In Chord mode, there is no Step Pitch Variation!
pitch
-  - **CV/CC Variation**: Randomly applies an offset to the **Step's MIDI CC Value** when triggering the **MIDI Note On Message**, and applies the same offset to the **{CV Output}**.
cv / cc

Note: All of these **Variation Tools** are super opinionated, and we've made choices to keep them musical. Any percentages you see are meant to communicate a vibe, not necessarily an honest representation of the math.

14 | Voice Modes : Chip Mode

14.01 - Chip Mode Overview

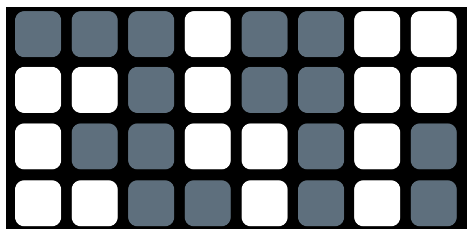

In **Chip Mode**, chords are sequenced and played as they are in **Chord Mode**, except rather than playing **Chords** over **MIDI**, and sending the root on the {Seq.x Outputs}, **Chip Mode** instead plays **Chords** using the **Arpeggiator** described in **Arp Mode**. When sequencing **Chip Chords** in **Step Mode**, the **Sequencer** behaves like **Chord Mode**, not **Mono Mode**.

The **Live Keyboard Layouts** in **Chip Mode** are exactly the same as in **Chord Mode**, and **Chip Chords** always have four notes.

14.02 - Chip Mode Channel Knobs

Programm's **Seq.x Channels** have six **Channel Value Settings** for each **Voice Mode**, one for each **Orange [Settings Knob]**. In **Chip Mode**, they are:



- **Shift**: Selects the **Arp Direction** for the **Arpeggiator**: Up, Down, Order, Random, Stochastic Random (doesn't reshuffle on repeats), up/down inclusive (repeats the top and bottom notes), up/down exclusive (doesn't repeat the top and bottom note), up 2 down 1, down/up inclusive, down/up exclusive, and down 2 up 1.



- **Length**: Changes the **Arpeggiator Gate Length**, the percentage of the **Arp Step** that the **Gate** will stay on from 1 to 100%.



- **Condition**: Applies an **Arp Condition Counter**, so that steps will sometimes skip (eg play the 1st and 3rd of every four **Arp Steps**).



- **Ratchet**: Selects from the 24 available **Chip Arp Clock Multiplications/Divisions** (**Arp clocks / Sequencer Clocks**), which can go much faster than **Arp Mode**: 6/1, 5/1, 4/1, 3/1, 2/1, 5/3, 3/2, 5/4, 1/1, 7/8, 6/7, 5/6, 4/5, 3/4, 2/3, 1/2, 3/7, 2/5, 3/8, 1/3, 2/7, 1/4, 1/5, and 1/6.



- **Pitch**: Selects from the 16 available **Arp Octave** settings: off, up 1, up 2, up 3, down 1, down 2, down 3, 25% random, 50% random, 75% random, 90% random, up 1-down 1, up/down 1, up/down 2, up/down 3, up/down 4, and up/down random.



- **CV/CC**: Sets the **Arpeggiator CV/CC Amount**, which increases or reduces the **CC/CV** value of each note in the **Arp** based on how far from the first note the **Arp Step** is.

14.03 - Chip Mode Channel Variation Settings

The **Variation Settings** in **Chip Mode** are identical to the **Variation Settings** in **Arp Mode**:



- **Shift Variation**: Randomly makes the **Arpeggiator** increment in the wrong direction or repeat an **Arp Step**.



- **Length Variation**: Randomizes the **Gate Length** of an **Arp Step** based on the **Length Variation** set.



- **Condition Variation**: Randomly skips triggering an **Arp Step**, applies a percentage chance of skipping an **Arp Step**.



- **Ratchet Variation**: Randomizes the **Arpeggiator Clock Multiplications/Divisions** every time the **Arpeggiator** resets.



- **Pitch Variation**: Randomizes the pitch of each **Arp Step**; in lower percentages you will get well tempered pitches, and in higher ranges odd-tempered intervals.



- **CV/CC Variation**: Randomly applies an offset to the **Arp Step's CC Value** when triggering the **MIDI Note On Message**, and applies the same offset to the {**CV Output**}.

15 | Mono/Arp Mode Keyboards

15.01 - Mono/Arp Mode Keyboard Layouts

The **Mono/Arp Mode Keyboard Layouts** are laid out such that scales are played in ergonomic patterns, and chords are intuitive shapes. Below are all the **Keyboard Layouts** shown in the Key of C. Under the notes is the **Octave Offset** associated with the note on the **Keyboard**. While these may seem intimidating at first, they become very musically useful with practice.

15.02 - Chromatic Keyboard Layout

C +1	C# +1	D +1	D# +1	E +1	F +1	F# +1	G +1
G# +0	A +0	A# +0	B +0	C +1	C# +1	D +1	D# +1
E +0	F +0	F# +0	G +0	G# +0	A +0	A# +0	B +0
C +0	C# +0	D +0	D# +0	E +0	F +0	F# +0	G +0

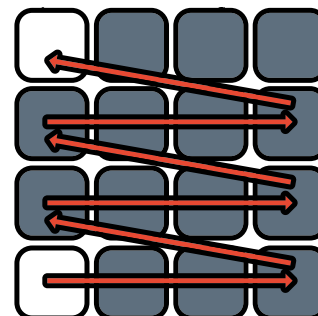

This is the pattern used for playing an ascending chromatic scale.

The **Chromatic Keyboard** in Programm is arranged such that pitches increase by one half-step per step as you move right, and by a major third per step as you move up.

15.03 - Major Keyboard Layout

E +1	F +1	G +1	A +1	B +1	C +2	D +2	E +2
B +0	C +1	D +1	E +1	F +1	G +1	A +1	B +1
F +0	G +0	A +0	B +0	C +1	D +1	E +1	F +1
C +0	D +0	E +0	F +0	G +0	A +0	B +0	C +1

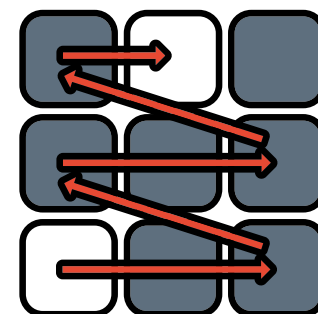

This is the pattern used for playing an ascending major scale.

The **Major Keyboard** in Programm is arranged such that pitches increase by one scale degree per step as you move right, and by a major fourth per step as you move up.

15 | Mono/Arp Mode Keyboards

15.04 - Minor Keyboard Layout

E _b +1	F +1	G +1	A _b +1	B _b +1	C +2	D +2	E _b +2
B _b +0	C +1	D +1	E _b +1	F +1	G +1	A _b +1	B _b +1
F +0	G +0	A _b +0	B _b +0	C +1	D +1	E _b +1	F +1
C +0	D +0	E _b +0	F +0	G +0	A _b +0	B _b +0	C +1

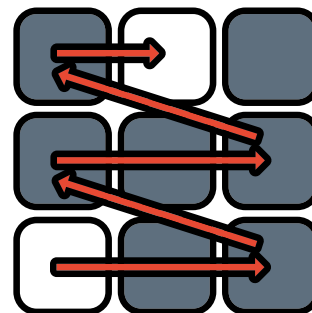

This is the pattern used for playing an ascending minor scale.

The **Minor Keyboard** in Programm is arranged such that pitches increase by one scale degree per step as you move right, and by a major fourth per step as you move up.

15.05 - Whole-Tone Keyboard Layout

F _# +1	A _b +1	B _b +1	C +2	D +2	E +2	F _# +2	A _b +2
C +1	D +1	E +1	F _# +1	A _b +1	B _b +1	C +2	D +2
F _# +0	A _b +0	B _b +0	C +1	D +1	E +1	F _# +1	A _b +1
C +0	D +0	E +0	F _# +0	A _b +0	B _b +0	C +1	D +1

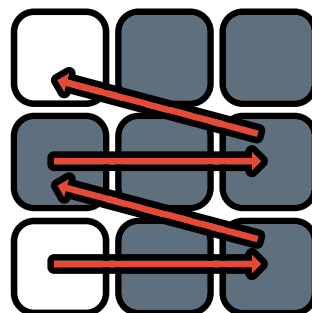

This is the pattern used for playing an ascending whole-tone scale.

The **Whole Tone Keyboard** in Programm is arranged such that pitches increase by one scale degree per step as you move right, and 4 whole tones per step as you move up.

15.06 - Pentatonic Keyboard Layout

A +1	C +2	D +2	E +2	G +2	A +2	C +3	D +3
D +1	E +1	G +1	A +1	C +2	D +2	E +2	G +2
G +0	A +0	C +1	D +1	E +1	G +1	A +1	C +2
C +0	D +0	E +0	G +0	A +0	C +1	D +1	E +1

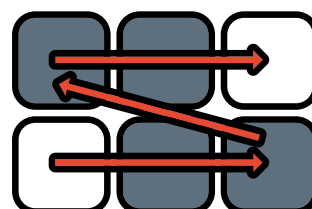

This is the pattern used for playing an ascending pentatonic scale.

The **Pentatonic Keyboard** in Programm is arranged such that pitches increase by one scale degree per step as you move right, and by a fifth per step as you move up.

16 | Chord/Chip Mode Keyboards

16.01 - Chord/Chip Mode Keyboard Layouts

The **Chord/Chip Mode Keyboard Layouts** are laid out such that playing scale patterns how you would in **Mono** or **Arp Mode** instead progress through the circle of fifths (or fourths). This creates a feeling of rising **Chords** as you move through **Scales**. Below are all the different layouts for the different **Scales** available shown in the **Key** of C. Note that all chords are played in roughly the same octave across the **Keyboard**.

16.02 - Chromatic Chord Layout

Major Pentatonic Progression				Minor Pentatonic Progression			
C Ma.9,6	G Maj.9	E Min.7	B Min.7	C Mi.9,6	G Min.9	E Maj.9	B Min.9
A^b Dim.	E^b Dim.	B^b Maj.	F Maj.	A^b Maj.	E^b Maj.	B^b Min.	F Min.
E Min.	B Dim.	G^b Maj.	D^b Dim.	E Dim.	B Maj.	G^b Dim.	D^b Maj.
C Maj.	G Maj.	D Min.	A Min.	C Min.	G Min.	D Maj.	A Dim.

Major Progression Minor Progression

The **Chromatic Chord Keyboard** in Programm is arranged such that root notes increase by one degree of the circle of fifths. The **Chromatic Chord Keyboard** is split down the center such the left half is the major progression, and the right half is the minor progression. The top eight buttons are two pentatonic progressions selected for flavor, entirely on the opinions of Luna.

16.03 - Major Chord Layout

D Min.7	A Min.7	E Min.7	B Min.7	F Maj.7	C Maj.9	G Maj.9	D Min.9
F Maj.	C Maj.7	G Maj.7	D Min.7	A Min.7	E Min.7	B Min.7	F Maj.7
A Min.	E Min.	B Dim.	F Maj.	C Maj.7	G Maj.7	D Min.7	A Min.7
C Maj.	G Maj.	D Min.	A Min.	E Min.	B Dim.	F Maj.	C Maj.7

The **Major Chord Keyboard** progresses through the major progression in fifths, with one diminished fifth progression from B to F. This maintains the same scale shape as in **Mono Mode**, but is a more intuitive layout to the ear than progressing root notes by scale degrees.

16 | Chord/Chip Mode Keyboards

16.04 - Minor Chord Layout



The **Minor Chord Keyboard** progresses through the minor progression in fifths (sometimes augmented or diminished). This maintains the same scale shape as in **Mono Mode**, but is a more intuitive layout to the ear than progressing root notes by scale degrees.

16.05 - Whole-Tone Chord Layout



The **Whole-Tone Chord Keyboard** progresses through the whole-tone scale in an alternating diminished fifth-augmented fifth pattern. The **Chord Voicings** in the **Whole-Tone Chord Keyboard** are the most opinionated of any of the **Chord Keyboard Layouts**, and give a dreamy spacy vibe.

16.06 - Pentatonic Chord Layout

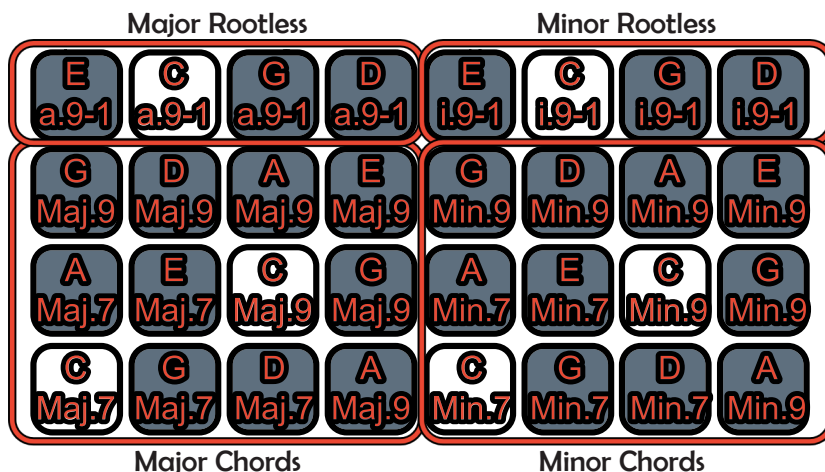

The **Pentatonic Chord Keyboard** moves through root notes in perfect fifths. Like the **Chromatic Chord Keyboard**, it splits the left and right sides into major and minor. The top row of chords are all rootless.

17.01 - Octave Offsets

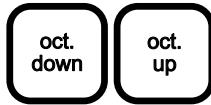

Programm has three different **Octave Offsets** to keep track of:

- **Live Keyboard Octave** - The octave used with notes played on the **Live Keyboard**.

Change the **Live Keyboard Octave** by using the [**Octave Buttons**] in **Live Mode**.

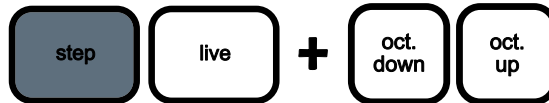

- **Sequence Octave** - The octave used by the **Sequencer**, dictating what octave notes will be played in which triggered.

Change the **Sequence Octave** in **Step Mode** by selecting a **Seq.x Channel** with the [**Seq.x Buttons**] and then using the [**Octave Buttons**] to transpose the sequence up or down Octaves.



Change the **Sequence Octave** in **Live Mode** by holding a [**Seq.x Button**] and then using the [**Octave Buttons**] to transpose the sequence up or down Octaves.



- **Step Octave** - The octave assigned to a **Sequence Step**.

To change a **Step's Step Octave**, select the **Step** in **Step Mode**, and then use the [**Octave Buttons**] to transpose that step up or down Octaves.



+5 Oct **Octave LEDs**

+4 Oct

+3 Oct

+2 Oct

+1 Oct **Max Octave Offset**

+0 Oct

-1 Oct

-2 Oct

-3 Oct

-4 Oct

-5 Oct

The (**Octave Button LEDs**) are used to communicate the currently selected **Octave Offset**, but also any time and **Octave Offset** is changed, the **Octave Offset** will be displayed on the (**Step Grid Button LEDs**). Faster blinking **Octave LEDs** communicates a larger offset.

The maximum **Octave Offset** for any target is +/- 5 Octaves. If ever a note is played outside of Programm's range, that note will be transposed up or down by whole octaves until it is inside Programm's range.

Octave Recording

When recording with the **Live Mode**, the **Step Octave Offset** will be recorded such that the **Sequencer Step** is played in the same **Octave** it was played in by the **Live Keyboard**, taking into account the **Sequence Octave**.

18 | Mutes

18.01 - Mutes

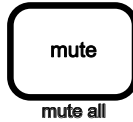

Programm's channels can be **Muted** to stop the **Sequencer** from triggering notes.

Channels can be muted individually with **Channel Mutes**, or all channels can be muted simultaneously with **Mute All**.

18.02 - Channel Mutes

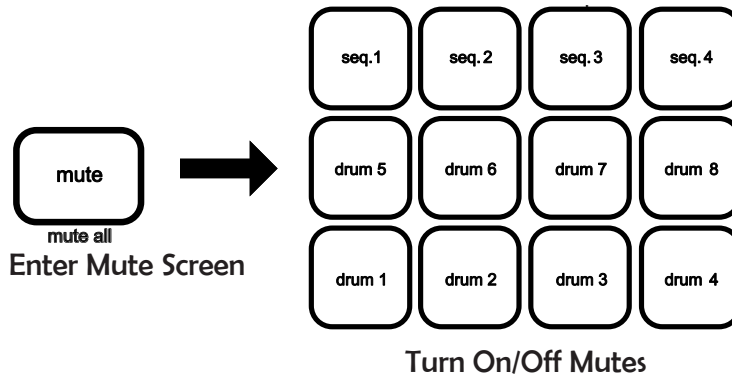

To **Mute** a **Channel**, enter the **Mute Screen** using the [**Mute Button**], then use any of the 12 [**Channel Buttons**] to enable and disable **Channel Mutes**.

18.03 - Mute All

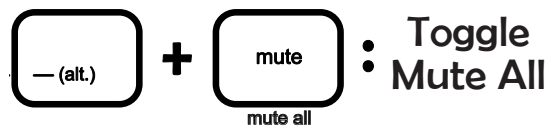

To **Mute** all of Programm's Channels, hold the [**Alt. Button**] and press [**Mute All**] to toggle **Mute All** on or off. While **Mute All** is on, the **Sequencer** will not play any notes, but **Live Mode** and **MIDI** input will still be able to play notes. While **Mute All** is on, the (**Mute Button LED**) will blink.

19 | Hold and Transpose

19.01 - Hold

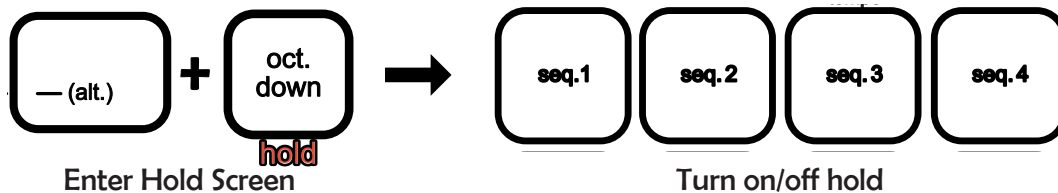

Programm's four **Seq.X Channels** have a **Hold** function, which changes the behavior of the gates and **Live Keyboard** for that **Channel**. To toggle on and off **Hold** for a **Channel**, use the **[Hold Button]** to enter the **Hold Screen**, then use the four **[Seq.X Buttons]** to toggle and off **Hold**.

While **Hold** is on, the **{Seq.x Gate Outputs}** will stay on, **MIDI Note Off Messages** will not send until the next **MIDI Note On Message** is sent on the **Channel**, the **Arpeggiator** will continue to play the same notes until new notes are loaded in, and the **Live Keyboard** will only turn off notes after the first note is played after all **[Step Grid Buttons]** are released.

19.02 - Transpose

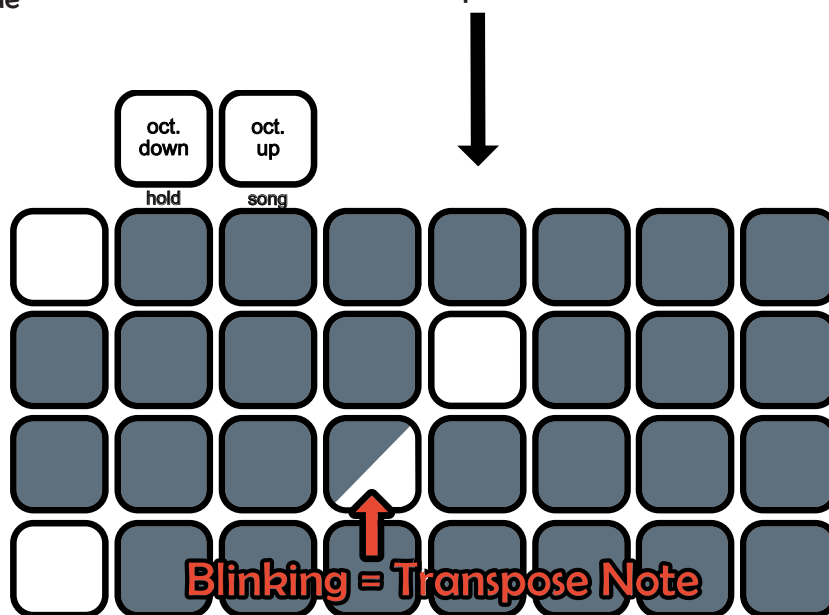

Each of Programm's four **Seq.x Channels** can be transposed using the **Transpose Function**.

To use **Transpose**, first enter **Transpose Mode** by using the **[Transpose Button]**. While in **Transpose Mode**, use the **[Seq.X Buttons]** to select the **Transpose Channels**, then use the **Transpose Keyboard** and **[Octave Buttons]** to transpose the **Sequencer** into different keys and octaves.

While in **Transpose Mode**, the **[Octave Buttons]** will change the octave of the **Transpose Keyboard**, but the octave will not be applied until a note is played on the **Transpose Keyboard**.

The **Transpose Keyboard** uses the same layout as the **Mono/Arp Mode Chromatic Keyboard** in the assigned key of the **Channel**.

20 | Division, Direction, and Quantize

20.01 - Clock Division

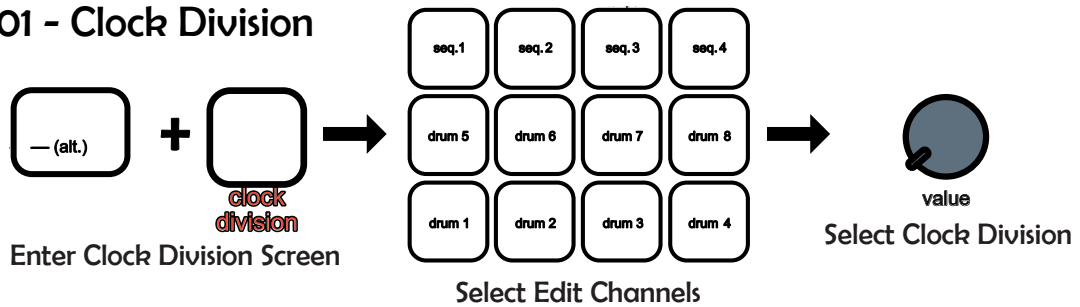

Each of Programms 12 **Sequencer Channels** has an independent **Clock Division** from 1 to 16. **Clock Division** changes the number of **Clock Ticks** that the **Sequencer Channel** will use as one **Step**, slowing down that channel by an integer division of time.

Change the **Clock Division** by first using the [**Clock Division Button**] to enter the **Clock Division Screen**, then using the [**Channel Buttons**] to select which **Sequencer Channels** you want to set the **Clock Division** for, then use the [**Value Knob**] to select a **Clock Division** from 1 to 16 for the selected **Channels**. If **Play** is active, the new **Clock Division** will take effect when the **Sequence** returns to its first step. If **Play** is inactive, the new **Clock Division** will be assigned immediately.

20.02 - Direction

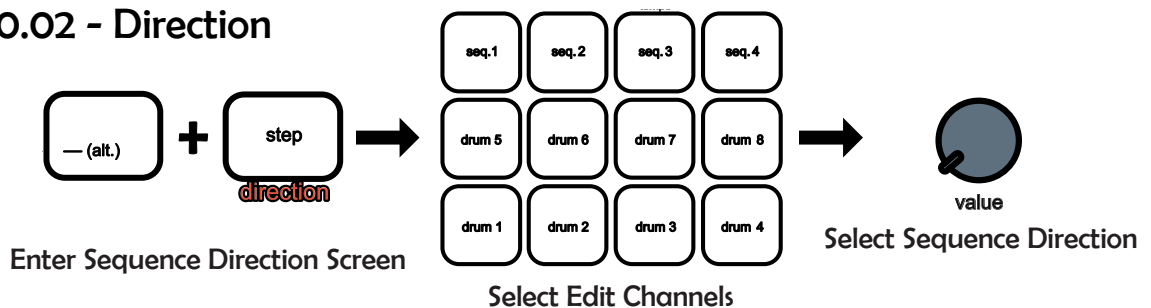

Each of Programms 12 **Sequencer Channels** has an independent **Sequence Direction**: Forward, Backward, or Random. **Sequence Direction** changes the direction that the Sequencer plays in, allowing users to reverse the sequence or randomize the step order.

Change the **Sequence Direction** by first using the [**Direction Button**] to enter the **Sequence Direction Screen**, then using the [**Channel Buttons**] to select which **Sequencer Channels** you want to set the **Sequence Direction** for, then use the [**Value Knob**] to select a **Sequence Direction** for the selected **Channels**. If **Play** is active, the new **Sequence Direction** will take effect when the **Sequence** returns to its first step. If **Play** is inactive, the new **Sequence Direction** will be assigned immediately.

20.03 - Quantize

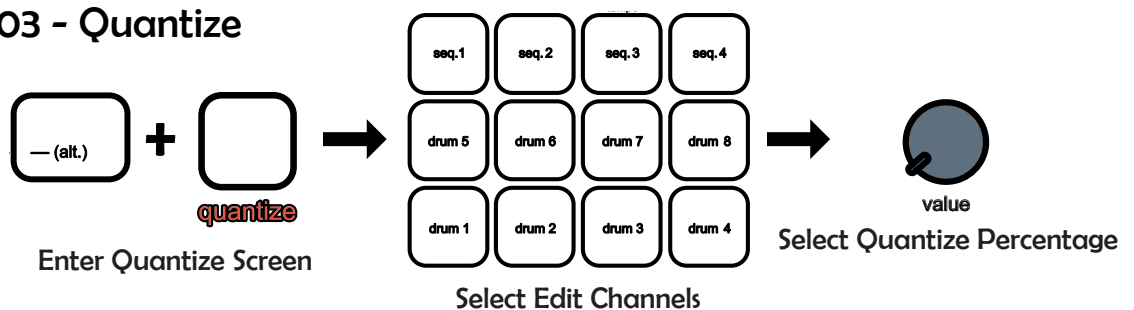

Each of Programms 12 **Sequencer Channels** can be **Quantized**. **Quantize** reduces the **Step Push** of all **Steps** in a **Sequence** by the **Quantize Percentage** set. This allow users to correct any timing errors they might have made while recording and lock all their steps to the grid.

Change the **Quantize Percentage** by first using the [**Quantize Button**] to enter the **Quantize Screen**, then using the [**Channel Buttons**] to select which **Sequencer Channels** you want to set the **Quantize Percentage** for, then use the [**Value Knob**] to select a **Quantize Percentage** from 0-100%.

21 | Groove

21.01 - What is Groove?

Groove is our answer to what we wish **Swing** was, expanding on the concepts of **Swing** timing to allow more interesting and exciting swing-feels and provide a quick way to automate any of the six parameters (**Shift, Length, Condition, Ratchet, Pitch, and CV/CC**) in a way that maintains an underlying musicality.

Groove uses an underlying counter to control each of the six different **Groove Algorithms** available in the **Groove Tool**.

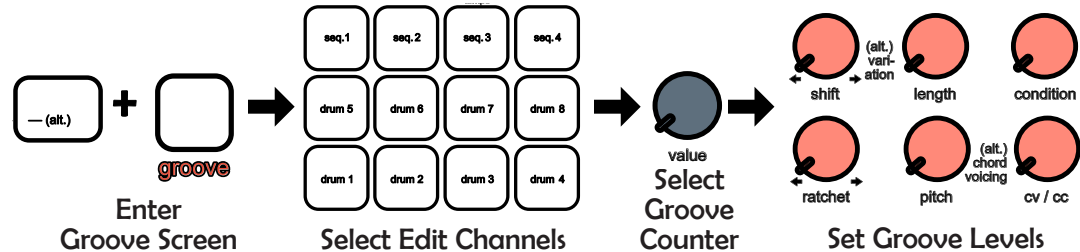

21.02 - The Groove Counter

The **Groove Counter** increments every **Step**, and is used to determine the behavior of the **Groove Algorithms** on each **Step**. Pick from the seven Groove Counters in the Groove Screen by using the **[Value Knob]**. The seven groove counters are:

One-Direction Counters	Up-Down Counters
<p>Two-Step (0, 1, 0, 1...)</p>	<p>Push-Pull in Four (0, 1/2, 1, 1/2, 0...)</p>
<p>Three-Step (0, 1/2, 1, 0...)</p>	<p>Push-Pull in Six (0, 1/3, 2/3, 1, 2/3, 1/3, 0...)</p>
<p>Four-Step (0, 1/3, 2/3, 1, 0...)</p>	<p>Push-Pull in Eight (0, 1/4, 1/2, 3/4, 1, 3/4, 1/2, 1/4, 0...)</p>
<p>Five-Step (0, 1/4, 1/2, 3/4, 1, 0...)</p>	

It's not super important to understand the math behind how groove works. What's important is playing with the different Groove Counters and getting a feel for them.

Groove gives access to the vibe of Kumbia, Afro-beat and other genres that live outside the American Jazz tradition of 1-2 swing.

21.03 - The Six Groove Algorithms for Drums

The six **Groove Algorithms** behave differently for **Seq.x Channels** and **Drum Channels**. For **Drum Channels**, they are:



- **Groove Shift:** Shifts the timing of drum hits forward or backward by up to a half step.



- **Groove Length:** Extends or shortens the **Gate Length** of the drum by +/- 50%.



- **Groove Condition:** Randomly skips steps with changing chance based on the **Groove**.



- **Groove Ratchet:** Applies ratchets to steps based on the **Groove**.



- **Groove Pitch:** Triggers the drum's alt **Midi Note #** based on the **Groove**.



- **Groove CV/CC:** Adds or subtracts to the **MIDI CC Value** of a step's **MIDI Note On Message**.

21.04 - The Six Groove Algorithms for Seq.x Channels

The six **Groove Algorithms** behave differently for **Seq.x Channels** and **Drum Channels**. For **Seq.x Channels**, they are:



- **Groove Shift:** Shifts the timing of steps forward or backward by up to a half step.



- **Groove Length:** Extends or shortens the **Gate Length** of steps by +/- 50%.



- **Groove Condition:** Randomly skips steps with changing chance based on the **Groove**.



- **Groove Ratchet:** Applies ratchets to steps based on the **Groove**.



- **Groove Pitch:** Sends **MIDI Pitch Bend** information based on the **Groove**.



- **Groove CV/CC:** Adds or subtracts to the **MIDI CC Value** of a step's **MIDI Note On Message**.

22 | Pattern Generator

22.01 - The Pattern Generator

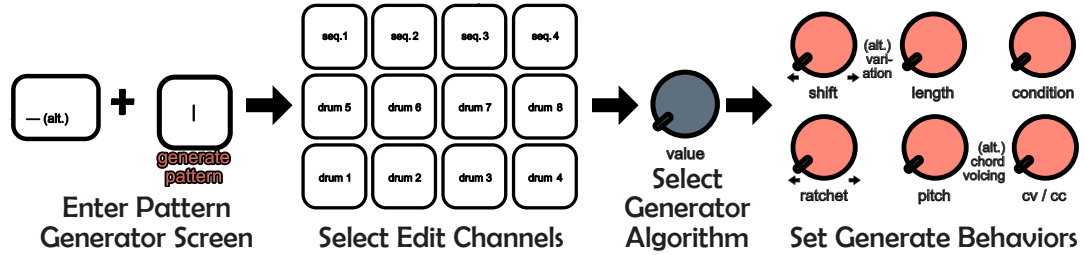

Programm has a **Pattern Generation** algorithm that generates full sequences to get a user started quickly. To generate a pattern, use the **[Generate Pattern]** button to enter the **Pattern Generator Screen**. Next, use the **[Channel Buttons]** to select which **Sequencer Channels** you want to **Generate Patterns** for. After selecting **Edit Channels**, use the **[Value Knob]** to select from one of the four **Generator Algorithms**. Finally, use the **Orange [Setting Knobs]** to control the behavior of the **Pattern Generator**.

22.02 - Generator Algorithms

The four Generator Algorithms change the underlying rhythm of the **Pattern Generator**. They are:

Generator Algorithms

	<p>Straight Time (Boots and Cats)</p>		<p>Mathy Time (Luna's Favorite)</p>
	<p>Syncopated Time (Dance Hall)</p>		<p>Generative Time (Algorithmic Meter)</p>

22.03 - Generate Behaviors

The six **Orange [Value Knobs]** each have an impact on how the **Pattern Generator** will generate patterns.

- **Generate Shift:** Controls how often **Steps** will have micro-timing.
- **Generate Length:** Controls how much variation in **Gate Length Steps** will have.
- **Generate Condition:** Controls how many of the **Steps** will be on; changes the density of **Steps**.
- **Generate Ratchet:** Controls how often generated **Steps** will have **Ratchets**.
- **Generate Pitch:** Controls how weird the **Pitch** choices for **Seq.x Channels** will be.
- **Generate CV/CC:** Controls how much **CV/CC** and **Drum Accent** variation the sequence will have.

22 | Pattern Generator

22.04 - Generator Drum Map

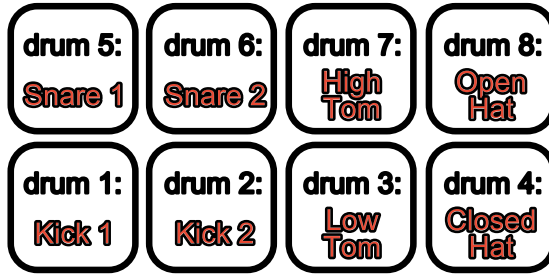

Programm's **Pattern Generator** makes some assumptions about what you're using the eight **Drum Channels** for. It will **Generate Drum 1 and Drum 2** as if they are kick drums, **Drum 3** as a low tom, **Drum 4** as a closed hat, **Drum 5 and Drum 6** as Snare Drums, **Drum 7** as a high tom, and **Drum 8** as an open hat.

22.05 - Generating Fills

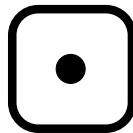

- Generate
- Pattern



- Generate
- Fill

If **Record** is On when the **Pattern** is **Generated**, the **Pattern** will over-write the current sequence. If **Record** is Off, the **Generated Pattern** will only play once through, as a **Fill**.

23 | Length and Extend

23.01 - Changing Sequence Length

Sequences in Programm can be up to 64 Steps. There are two tools for changing **Sequence Length**: the **Length Tool**, and the **Extend Tool**.

23.02 - The Length Tool

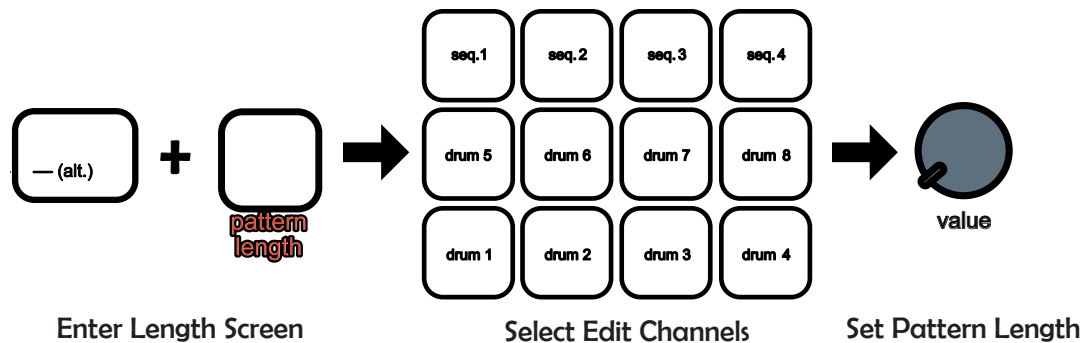

The **Length Tool** changes the **Sequence Length**, and any added **Steps** will be empty. To change **Sequence Length** with the **Length Tool**, first use the [**Pattern Length Button**] to enter the **Length Screen**, then using the [**Channel Buttons**] to select which **Sequencer Channels** you want to set the **Sequence Length** for, then use the [**Value Knob**] to select a **Sequence Length** from 1 to 64.

If **Play** is **Active**, the **Sequence Length** will change when the **Channel** returns to its first step. If **Play** is **Inactive**, the **Sequence Length** will change immediately.

23.03 - The Extend Tool

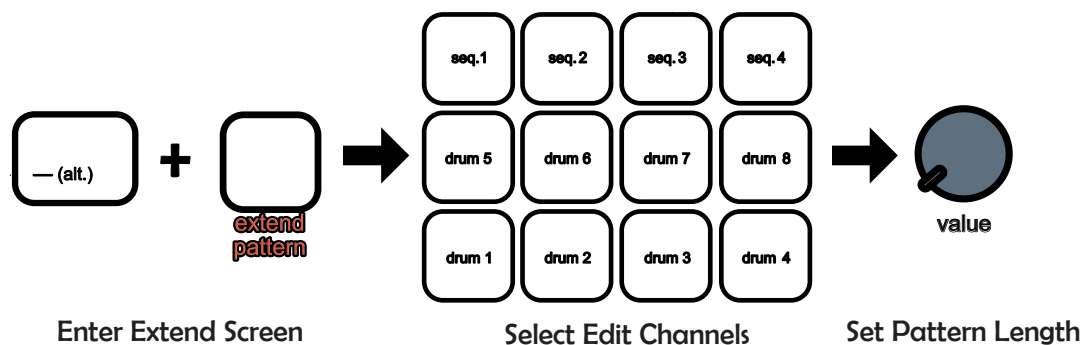

The **Extend Tool** changes the **Sequence Length**, and any added **Steps** will be filled as a copy of the pattern already programmed in from the first step.

To change **Sequence Length** with the **Extend Tool**, first use the [**Extend Pattern Button**] to enter the **Extend Screen**, then using the [**Channel Buttons**] to select which **Sequencer Channels** you want to **Extend**, then use the [**Value Knob**] to select a **Sequence Length** from 1 to 64.

If **Play** is **Active**, the **Sequence** will **Extend** when the **Channel** returns to its first step. If **Play** is **Inactive**, the **Sequence** will **Extend** immediately.

24 | Chance Input

24.01 - Chance Input

chance
in



The {Chance Input} is another way to apply randomization to **Patterns** in Programm. By sending CV into the {Chance Input} and turning up the **Chance In Amounts**, a user can modulate any of the **Variation Settings** described throughout this manual.

The {Chance Input} will default high until a CV source is sent into it.

24.02 - Chance In Amount

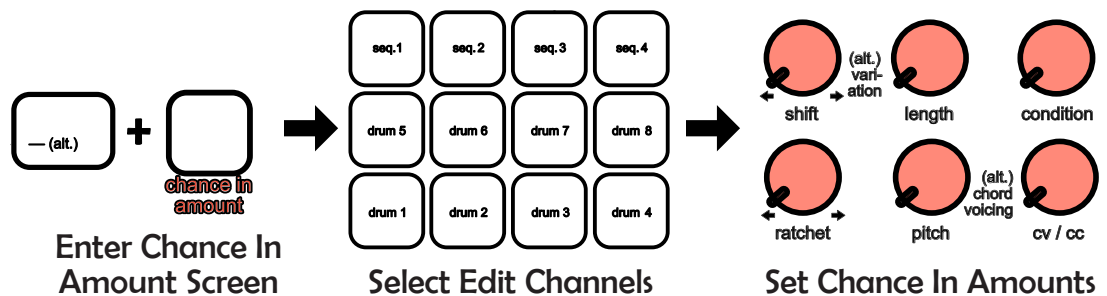

Chance In Amount controls how much the {Chance Input} effects each of the **Variation Settings**.

To change **Chance In Amounts**, first use the **[Chance In Amount Button]** to enter the **Chance In Amount Screen**, then using the **[Channel Buttons]** to select which **Sequencer Channels** you want to apply chance to, then use the **Orange [Settings Knobs]** to set the **Chance In Amount** for that knob.

25 | Midi Settings

25.01 - The MIDI Screen



The **MIDI Screen** is used to edit three midi settings: **MIDI Channel**, **MIDI CC Channel**, and **MIDI Thru**.

25.02 - MIDI Channel

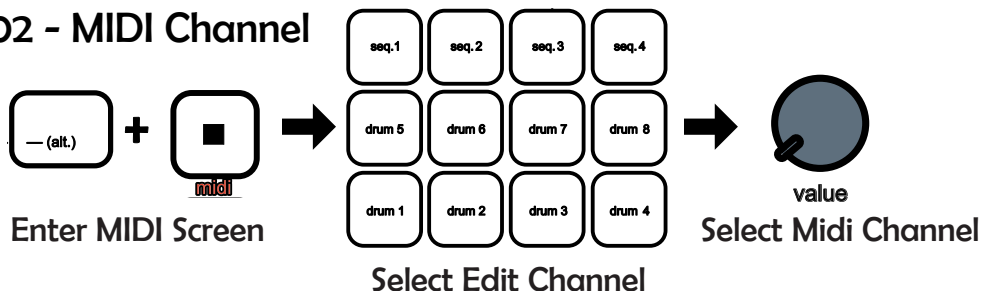

Programm has five **MIDI Channels**: One shared between all eight **Drum Channels**, and one for each **Seq.x Channel**. By default, the **Drum Channels** are on **MIDI Channel 10**, and the **Seq.x Channels** are on **MIDI Channels 1,2,3 and 4** respectively.

To change the **MIDI Channels**, first use the **[MIDI Button]** to enter the **MIDI Screen**, then use the **[Channel Buttons]** to select which **Sequencer Channels** you want to edit, then use the **[Value Knob]** to set the **MIDI Channel** from 1 to 16.

25.03 - MIDI CC Channel

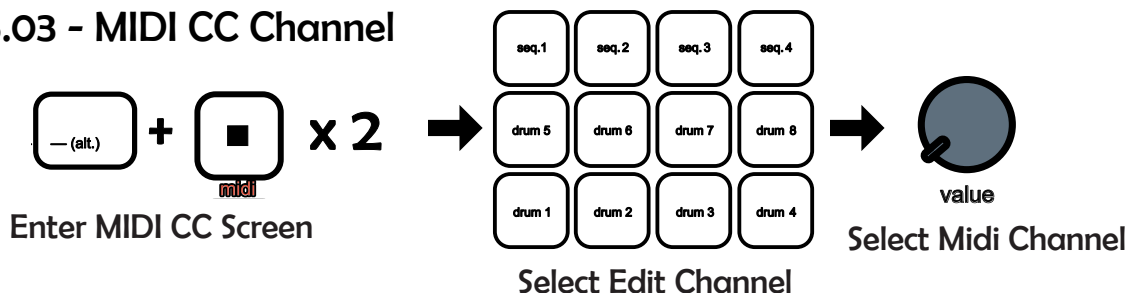

Programm has five **MIDI CC Channels**: One shared between all eight **Drum Channels**, and one for each **Seq.x Channel**. By default, all **MIDI CC Channels** are set to **Velocity Only**. The **MIDI CC Channel** specifies a **MIDI CC Channel** that the **Sequencer Channel** will send CV/CC values on separate to **MIDI Note On Velocity**.

To change the **MIDI CC Channels**, first use the **[MIDI Button]** to enter the **MIDI Screen**, then use the **[MIDI Button]** again to navigate to the **MIDI CC Channel** secondary setting screen. Next, use the **[Channel Buttons]** to select which **Sequencer Channels** you want to edit, then use the **[Value Knob]** to set the **MIDI CC Channel** from 0 to 120.

25.04 - MIDI Thru

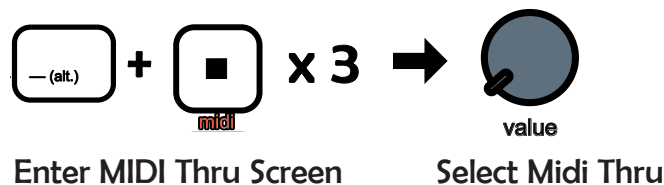

Programm support **MIDI Thru**. To activate **MIDI Thru**, first use the **[MIDI Button]** to enter the **MIDI Screen**, then use the **[MIDI Button]** two more times to navigate to the **MIDI Thru** secondary setting screen. Next, use the **[Value Knob]** to set the **MIDI Thru** to **Out** or **Thru**.

26 | Using External MIDI Controllers

26.01 - MIDI to CV Conversion

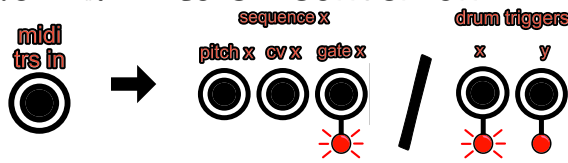

Programm functions as a robust MIDI to CV converter, where external MIDI Note On and Off messages can control any of Programm's 12 Sequencer Channels.

26.02 - MIDI Controlling Drum Channels

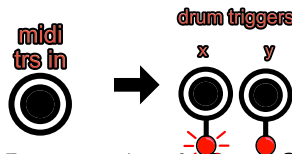

Programm's eight **Drum Channels** share a single **MIDI Channel**, and each of the eight **Drum Channels** has its own **MIDI Note #**. Whenever a **Note On Message** is received with a **Drum's MIDI Note #** on the **Drum MIDI Channel**, the **Drum Channel** will play a note. If **Play** and **Record** are both **Active**, the note will be recorded into its respective **Drum Channel's Sequencer**.

26.03 - MIDI Controlling Seq.x Channels

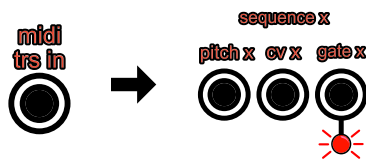

Programm's four **Seq.x Channels** each have their own **MIDI Channel**. When external **MIDI Note On Messages** are received on any of the **Seq.x Channels' MIDI Channels**, the respective **Seq.x Channel** will play a note as if that note was played on the **Live Mode Grid Keyboard**. If **Play** and **Record** are both **Active**, the note will be recorded into its respective **Drum Channel's Sequencer** as it would be in the **Seq.x Channel's respective Voice Mode**.

Using **MIDI** with **Seq.x Channels** works with all the of the **Seq.x Channel Voice Modes**, meaning that all of the powerful **Arpeggiator** and **Chord** tools available in Programm interact with external **MIDI** controllers.

26.04 - MIDI TRS Type A



Programm uses the **MIDI TRS Type A** for its **MIDI Adapter** standard. The provided **MIDI Adapter** is compatible with **MIDI TRS Type A**. When purchasing more **MIDI Adapters**, please make sure you are purchasing the correct standard.

27 | Saving and Loading Sequences

27.01 - Save Slots

Programm has 64 **Save Slots** for saving and loading **Sequences**. Each **Save Slot** contains all the **Step Settings** and **Channel Settings** for all 12 **Sequences**.

27.02 - Saving Sequences

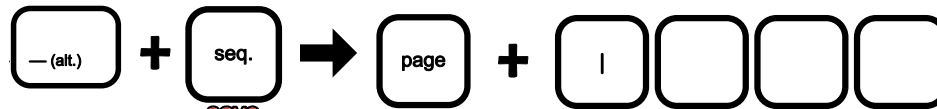

Enter Save Screen

Select Save Slot

To **Save** a **Sequence** with Programm, first use the [**Save Button**] to enter the **Save Screen**. While in the **Save Screen**, the (**Step Grid LEDs**) will show all the **Save Slots** that have data stored. Page one of the **Save Screen** shows **Save Slots** 1 through 32, to see **Save Slots** 33 through 64 use the [**Page Button**]. To **Save** the **Sequence**, press any of the [**Step Grid Buttons**] to select a **Save Slot** and the data in that **Save Slot** will be overwritten with the current **Sequence**. When **Saving Sequences**, all 12 **Sequencer Channels** are **Saved** to a **Save Slot** simultaneously.

Important note: due to hardware limitations, **Sequences** cannot be **Saved** while **Play** is **Active**! If a **Save** is performed while **Play** is **Active**, that **Save** will take effect after **Play** is **Stopped**. If a second **Save** is activated before **Play** has **Stopped**, only the second **Save** will take effect! Any changes to the **Sequence** made after a **Save** is activated will be present in the **Save** performed when **Play** is **Stopped**.

27.03 - Loading Sequences

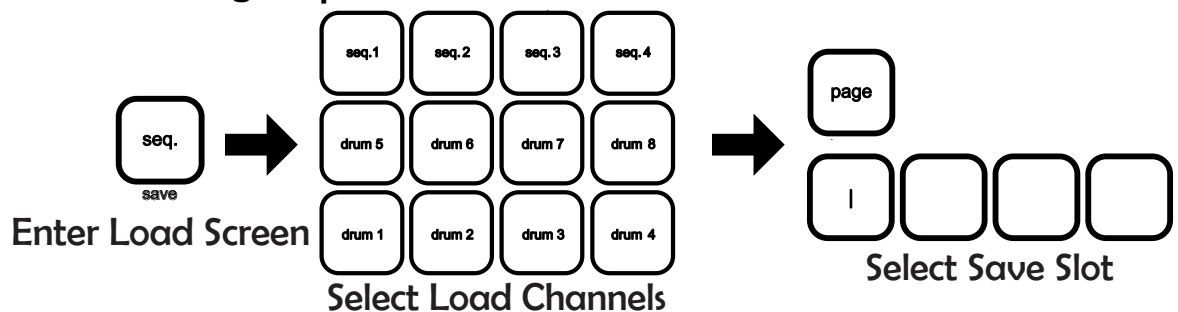

Enter Load Screen

Select Load Channels

Select Save Slot

To **Load** a **Sequence** with Programm, first use the [**Seq. Button**] to enter the **Seq. Load Screen**. While in the **Seq. Load Screen**, the (**Step Grid LEDs**) will show all the **Save Slots** that have data stored, and the current active **Save Slots** will be blinking. If the currently Active **Save Slots** have data stored, they will blink quickly and if not they will blink slowly. Page one of the **Seq. Load Screen** shows **Save Slots** 1 through 32, to see **Save Slots** 33 through 64 use the [**Page Button**].

Sequence Channels can have different active **Save Slots**, and you can **Load** just some of the **Sequence Channels** from a **Save Slot**. Select the **Sequence Channels** you want to **Load** using the [**Channel Buttons**]. To **Load** the **Sequence**, press any of the [**Step Grid Buttons**] to select a **Save Slot** and the data in that **Save Slot** will be **Loaded** into the selected **Sequence Channels**. If **Play** is **Active**, the **Load** will occur when the **Sequence** returns to its first **Step**.

27.04 - Clearing Save Slots

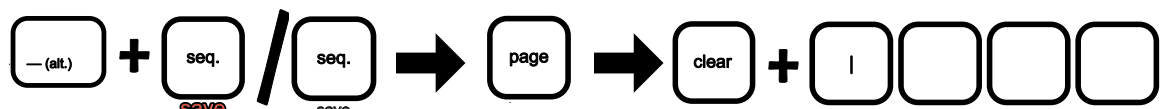

Enter Save/Load Screen

Navigate to Page

Clear Save Slot

While in the **Save Screen** or the **Seq. Load Screen**, holding the [**Clear Button**] and using the [**Step Grid Buttons**] will delete any active **Save Slots** pressed.

27.05 - Load Startup

Programm loads the last **Active Save Slot** on start-up.

28 | Clear Tool

28.01 - Clear Tool

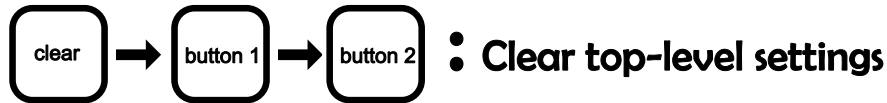

Programm's **Clear Tool** is a super powerful tool that is used to reset the values of any function in Programm to default settings. Note: Knobs can be bumped for button 2.





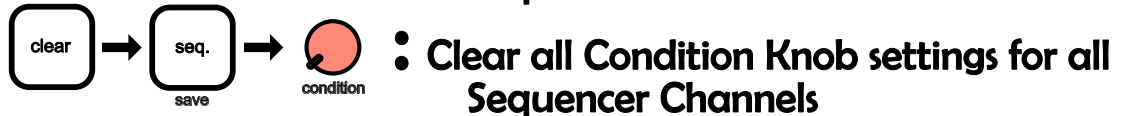



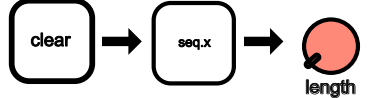

28.02 - Everything you can Clear (Top-Level Globals)

Here are the button combinations for everything the **Clear Tool** can be used to **Clear**:

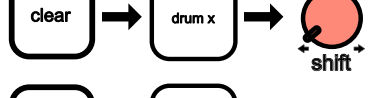
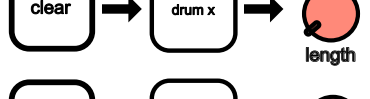
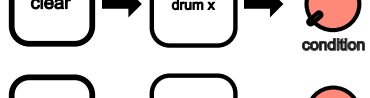

28 | Clear Tool

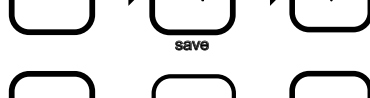
28.02 - Everything you can Clear(Channel Knobs + Steps)

- 
• Clear all Shift Knob settings for a Seq.x Channel
- 
• Clear all Length Knob settings for a Seq.x Channel
- 
• Clear all Condition Knob settings for a Seq.x Channel
- 
• Clear all Ratchet Knob settings for a Seq.x Channel
- 
• Clear all Pitch Knob settings for a Seq.x Channel
- 
• Clear all CV/CC Knob settings for a Seq.x Channel
- 
• Clear all Shift Knob settings for a Drum Channel
- 
• Clear all Length Knob settings for a Drum Channel
- 
• Clear all Condition Knob settings for a Drum Channel
- 
• Clear all Ratchet Knob settings for a Drum Channel
- 
• Clear all Pitch Knob settings for a Drum Channel
- 
• Clear all CV/CC Knob settings for a Drum Channel
- 
• Clear a Step for all Channels
- 
• Clear a Step in a Seq.x Channel
- 
• Clear a Step in a Drum Channel

28.02 - Everything you can Clear (Variation Settings)





























































- | | | | | | | | |
|-------|---|--------|---|--------|---|-----------|---|
| clear | → | (alt.) | → | seq. | → | shift | • Clear all Shift Variation settings for all Sequencer Channels |
| clear | → | (alt.) | → | seq. | → | length | • Clear all Length Variation settings for all Sequencer Channels |
| clear | → | (alt.) | → | seq. | → | condition | • Clear all Condition Variation settings for all Sequencer Channels |
| clear | → | (alt.) | → | seq. | → | ratchet | • Clear all Ratchet Variation settings for all Sequencer Channels |
| clear | → | (alt.) | → | seq. | → | pitch | • Clear all Pitch Variation settings for all Sequencer Channels |
| clear | → | (alt.) | → | seq. | → | cv / cc | • Clear all CV/CC Variation settings for all Sequencer Channels |
| clear | → | (alt.) | → | seq.x | → | shift | • Clear all Shift Variation settings for a Seq.x Channel |
| clear | → | (alt.) | → | seq.x | → | length | • Clear all Length Variation settings for a Seq.x Channel |
| clear | → | (alt.) | → | seq.x | → | condition | • Clear all Condition Variation settings for a Seq.x Channel |
| clear | → | (alt.) | → | seq.x | → | ratchet | • Clear all Ratchet Variation settings for a Seq.x Channel |
| clear | → | (alt.) | → | seq.x | → | pitch | • Clear all Pitch Variation settings for a Seq.x Channel |
| clear | → | (alt.) | → | seq.x | → | cv / cc | • Clear all CV/CC Variation settings for a Seq.x Channel |
| clear | → | (alt.) | → | drum x | → | shift | • Clear all Shift Variation settings for a Drum Channel |
| clear | → | (alt.) | → | drum x | → | length | • Clear all Length Variation settings for a Drum Channel |
| clear | → | (alt.) | → | drum x | → | condition | • Clear all Condition Variation settings for a Seq.x Channel |
| clear | → | (alt.) | → | drum x | → | ratchet | • Clear all Ratchet Variation settings for a Seq.x Channel |
| clear | → | (alt.) | → | drum x | → | pitch | • Clear all Pitch Variation settings for a Seq.x Channel |
| clear | → | (alt.) | → | drum x | → | cv / cc | • Clear all CV/CC Variation settings for a Seq.x Channel |

28 | Clear Tool

28.02 - Everything you can Clear (Variation Settings + Alt. Settings)

- Clear all Variation settings for all Sequencer Channels
- Clear all Variation settings for a Seq.x Channel
- Clear all Variation settings for a Drum Channel
- Set Direction to Forward for all Sequencer Channels
- Set Direction to Forward for a Seq.x Channel
- Set Direction to Forward for a Drum Channel
- Set Direction to Forward for all Sequencer Channels
- Set Direction to Forward for a Seq.x Channel
- Set Direction to Forward for a Drum Channel
- Set Tempo to 145bpm
- Set Mute All to off.
- Turn off Transpose for all Channels.
- Turn off Hold for all Channels.
- Reset all MIDI Settings to defaults.
- Reset all MIDI Channel and CC to default for a Seq.x Channel.
- Reset all MIDI Channel and CC to default for Drum Channels.
- Reset all Clock Settings to defaults.

28.02 - Everything you can Clear(Alt. Function Settings)

-  →  →  →  : Reset all Clock Settings to defaults.
-  →  →  →  : Reset Key and Scale to C Chromatic for all Seq.x Channels.
-  →  →  →  : Reset Key and Scale to C Chromatic for a chosen Seq.x Channel.
-  →  →  →  : Reset Clock Divisions for all Channels.
-  →  →  →  : Reset Clock Division for a Seq.x Channel.
-  →  →  →  : Reset Clock Division for a Drum Channel.
-  →  →  →  : Reset Quantize for all Channels.
-  →  →  →  : Reset Quantize for a Seq.x Channel.
-  →  →  →  : Reset Quantize for a Drum Channel.
-  →  →  →  : Reset Groove for all Channels.
-  →  →  →  : Reset Groove for a Seq.x Channel.
-  →  →  →  : Reset Groove for a Drum Channel.
-  →  →  →  : Set Seq. Length to 32 steps for all Channels.
-  →  →  →  : Set Seq. Length to 32 steps for a Seq.x Channel.
-  →  →  →  : Set Seq. Length to 32 steps for a Drum Channel.

28 | Clear Tool

28.02 - Everything you can Clear(Alt. Function Settings)

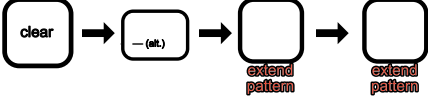
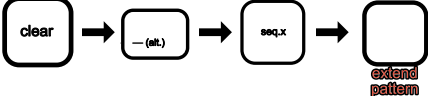
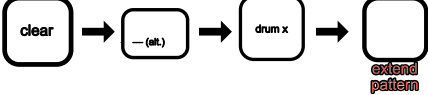
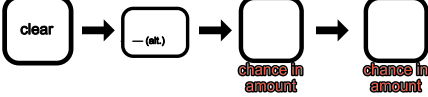
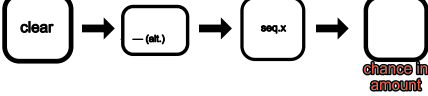
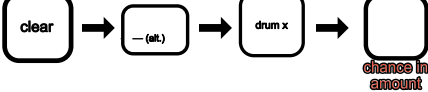
-  : Extend Seq. Length to 32 steps for all Channels.
-  : Extend Seq. Length to 32 steps for a Seq.x Channel.
-  : Extend Seq. Length to 32 steps for a Drum Channel.
-  : Turn off chance in for all Channels.
-  : Turn off chance in for a Seq.x Channel.
-  : Turn off chance in for a Drum Channel.

29 | Copy Tool

29.01 - Copy Tool

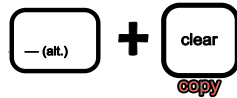

Programm's **Copy Tool** is perhaps a bit less powerful than the **Clear Tool**, but it is decidedly simpler and quicker to use.

The **Copy Tool** can be used to **Copy Steps** inside a **Sequencer Channel**, or to **Copy** an entire **Drum Channel** into another **Drum Channel**, or to **Copy** an entire **Seq.x Channel** into another **Seq.x Channel**.

29.02 - Copy a Drum Channel

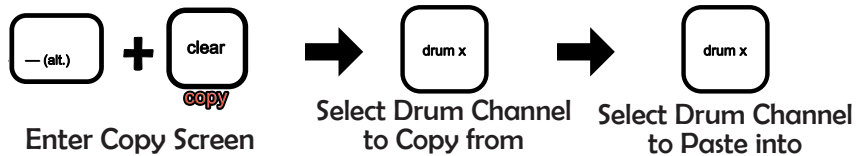

To **Copy a Drum Channel**, first use the **[Copy Button]** to enter the **Copy Screen**. Next, use any **[Drum Button]** to select the **Drum Channel** you want to **Copy** from. Next use any other **[Drum Button]** to select a **Drum Channel** to **Paste** into.

Copying a **Drum Channel** will **Copy** over everything that can be **Saved** when **Saving a Sequence**.

After **Copying a Drum Channel**, the **Copy Tool** will reset to as it was when you entered the **Copy Screen**, and another **Copy** can be performed.

29.03 - Copy a Seq.x Channel



To **Copy a Seq.x Channel**, first use the **[Copy Button]** to enter the **Copy Screen**. Next, use any **[Seq.x Button]** to select the **Seq.x Channel** you want to **Copy** from. Next use any other **[Seq.x Button]** to select a **Seq.x Channel** to **Paste** into.

Copying a **Seq.x Channel** will **Copy** over everything that can be **Saved** when **Saving a Sequence**.

After **Copying a Seq.x Channel**, the **Copy Tool** will reset to as it was when you entered the **Copy Screen**, and another **Copy** can be performed.

29.04 - Copy a Step

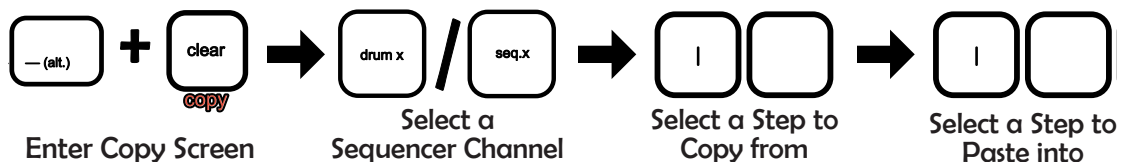

To **Copy a Step**, first use the **[Copy Button]** to enter the **Copy Screen**. Next, use any **[Channel Button]** to select the **Sequencer Channel** you want to **Copy** inside of. Next, use any **[Step Grid Button]** to select a **Step** to **Copy** from. Finally, use any **[Step Grid Button]** to select a **Step** to **Paste** into.

Copying a **Step** will **Copy** all the **Step Knob Values** and **Step Variation Values** associated with a **Step**.

After **Copying a Step**, the **Copy Tool** will reset to as it was after a **Sequencer Channel** was selected, and another **Step Copy** can be performed. To reset the **Copy Tool**, select the active **Sequencer Channel** again.

30 | Song Mode

30.01 - Song Mode

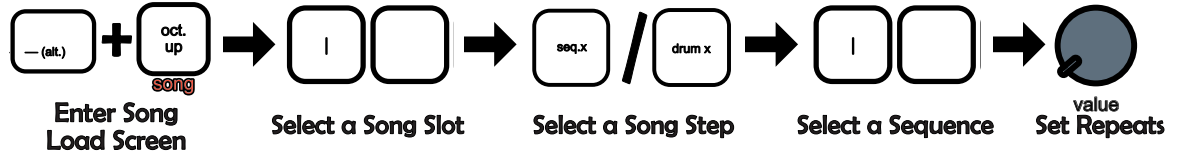

Programm's **Song Mode** allows users to create chains of **Sequences** that can be saved and played back later as **Songs**. **Song Mode** does not work like any of Programm's other screens, so you'll have to re-learn the ui for **Song Mode**.

30.02 - Song Load Screen

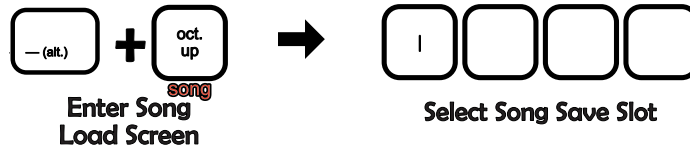

To use **Song Mode**, first use the **[Song Button]** to enter the **Song Load Screen**. If you entered the **Song Load Screen** by accident, no worries! Simply use the **[Edit Button]** to return to **Step Mode**.

The **Song Load Screen** works similarly to the **Sequence Load Screen**, where use **Song Save Slots** are lit, unused **Song Save Slots** are unlit, and the currently active **Song Save Slot** is blinking. Select any of the 32 **Song Save Slots** to enter the **Song Screen**.

30.03 - What is a song?

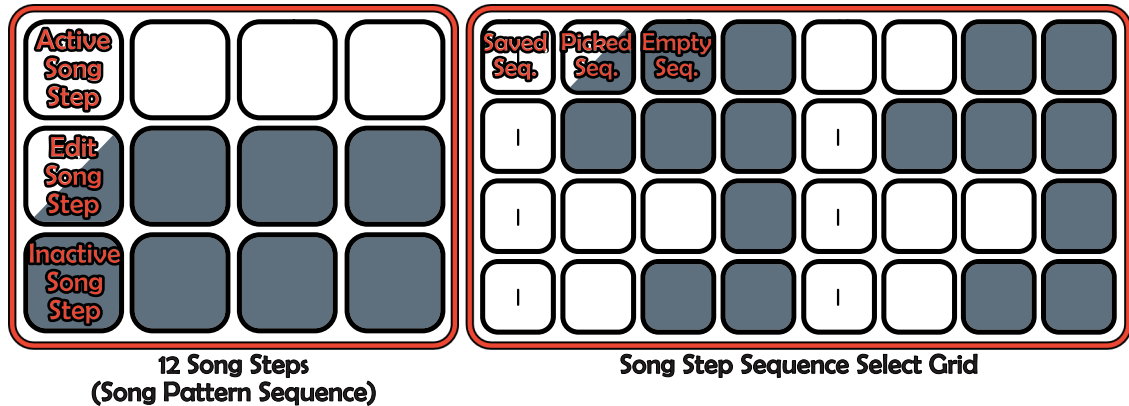

Songs in Programm are a collection of **Song Steps** that are played in order. **Songs** are 12 **Song Steps** long, and each **Song Step** is an active **Sequence** and a **Repeat** counter.

30.04 - Building a Song

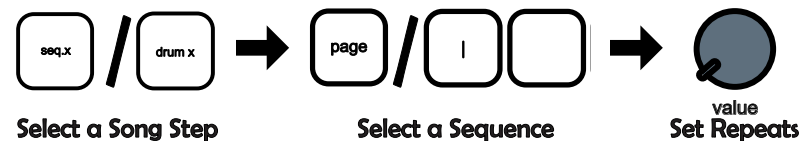

To build a **Song**, use the **[Channel Buttons]** to select a **Song Step** to edit. Use the **[Step Grid Buttons]** and **[Page Button]** to select the active **Sequence** for the **Song Step**. Use the **[Value Knob]** to set the number of **Repeats** from 1 to 16.

Continue this with each **Song Step** until you've built your **Song!**

30 | Song Mode

30.05 - Clearing a Song Step

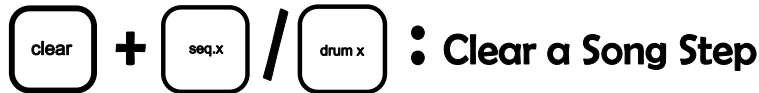

While building a **Song**, **Song Steps** can be **Cleared** by holding the **[Clear Button]** and using any active **[Channel Button]** to **Clear** the associated **Song Step**.

30.06 - Saving a Song



To use **Song Mode**, first use the **[Song Button]** to enter the **Song Load Screen**. If you entered the **Song Load Screen** by accident, no worries! Simply use the **[Edit Button]** to return to **Step Mode**.

The **Song Load Screen** works similarly to the **Sequence Load Screen**, where use **Song Save Slots** are lit, unused **Song Save Slots** are unlit, and the currently active **Song Save Slot** is blinking. Select any of the 32 **Song Save Slots** to enter the **Song Screen**.

30.07 - Play a Song



To **Play** your **Song**, press the **[Play Button]**, and the **Song Steps** will be played in the order you arranged them.



To **Stop** the **Song**, press the **[Stop Button]**. The **Song** will remember the last **Song Step**, and restart from there at the next **Play**. To reset the **Song** to the first **Song Step**, press the **[Stop Button]** again.

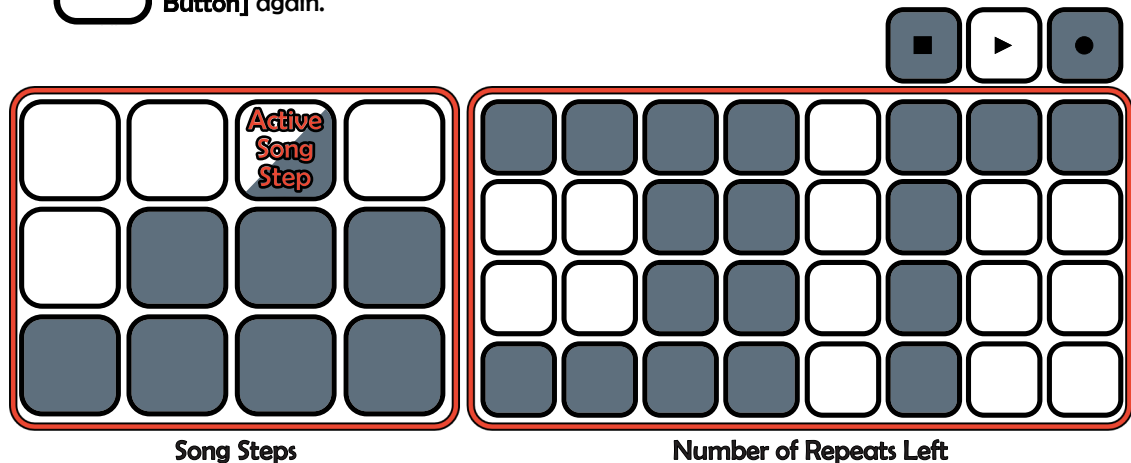

While a **Song** is playing, the playing **Song Step** is blinking, and the number of **Repeats** left of that **Song Step** are displayed on the (**Step Grid LEDs**).

30.08 - Song Corruption

Please note! If you change or overwrite any of the **Sequence Save Slots** used by a **Song**, that **Sequence** will also change in the **Song**! If your **Songs** are precious, please be careful with this!

31 | Clock and Reset Jacks

31.01 - Clock and Reset Input Electrical Characteristics

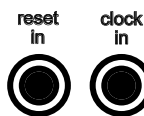

Programm's **{Clock Input}** and **{Reset Input}** are digital inputs that responds to logic high of 1 volt. They are protected inputs, so can receive any euro-rack level voltage without issue.

31.02 - Reset Input



Programm's **{Reset Input}** returns the **Sequencer** to step 1 when a gate is received, regardless of the **Clock Source**.

31.03 - Clock Input



Programm's **{Clock Input}** receives an analog clock signal to control the clock rate in **External Clock Mode**.

31.04 - Reset Output



Programm's **{Reset Output}** sends a 5-volt, 10ms analog gate pulse any time the **Sequencer** is started or stopped, any time a gate is received by the **{Reset Input}**, any time a **Midi Clock Start Message** is received during play with **MIDI Thru Off**, and any time the **[Play Button]** is pressed during play.









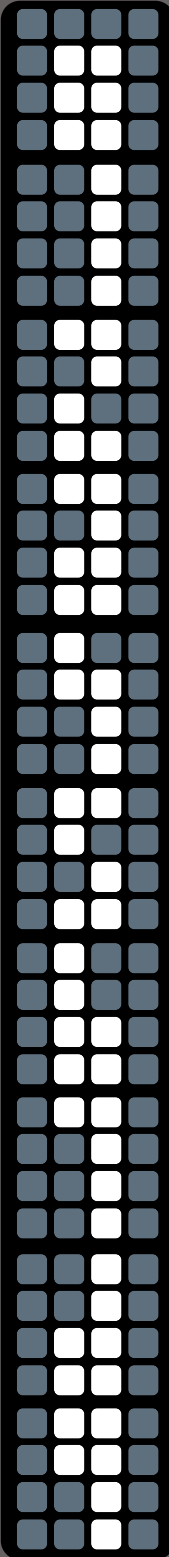
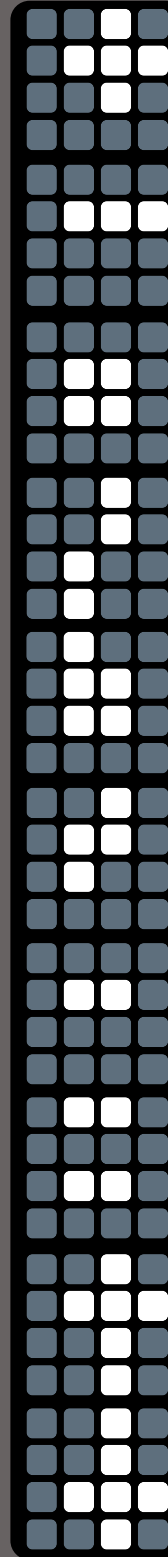
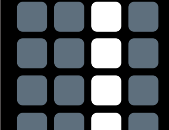
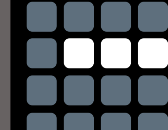
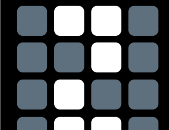
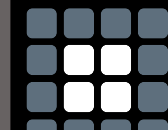
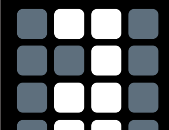

31.05 - Clock Output

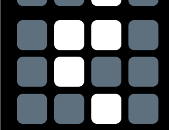
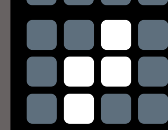
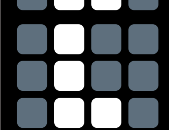
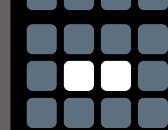

Programm's **{Clock Output}** sends 5-volt analog clock pulses any time the **Sequencer** is playing. The rate and pulse width of those gate signals is based on the **Clock Output Multiplication** standard selected.

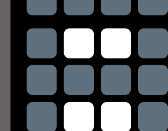
32 | Screen Legend

32.01 - Numbers and Special Characters

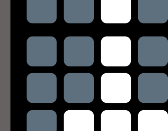
Numbers	Special Characters
 Zero	 Plus
 One	 Minus
 Two	 Multiply
 Three	 Divide
 Four	 Flat
 Five	 Sharp
 Six	 -1 Octave
 Seven	 -2 Octave
 Eight	 Up
 Nine	 Down

32 | Screen Legend

32.02 - Letters Aa - Rr

Aa - li	Jj - Rr
A a	J j
B b	K k
C c	L l
D d	M m
E e	N n
F f	O o
G g	P p
H h	Q q
I i	R r

32 | Screen Legend

32.03 - Letters Ss - Zz, Groove Modes, No/Off Screen

Ss - Zz(+No/Off)

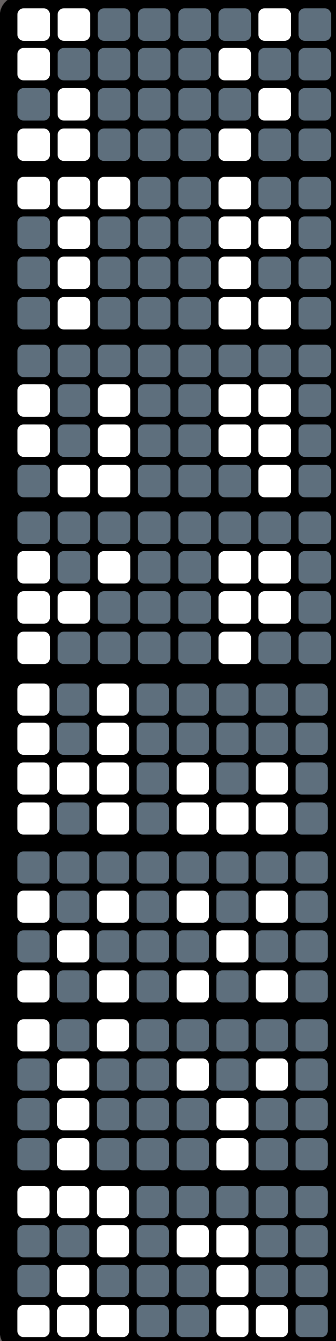

S s

T t

U u

V v

W w

X x

Y y

Z z

Groove Modes

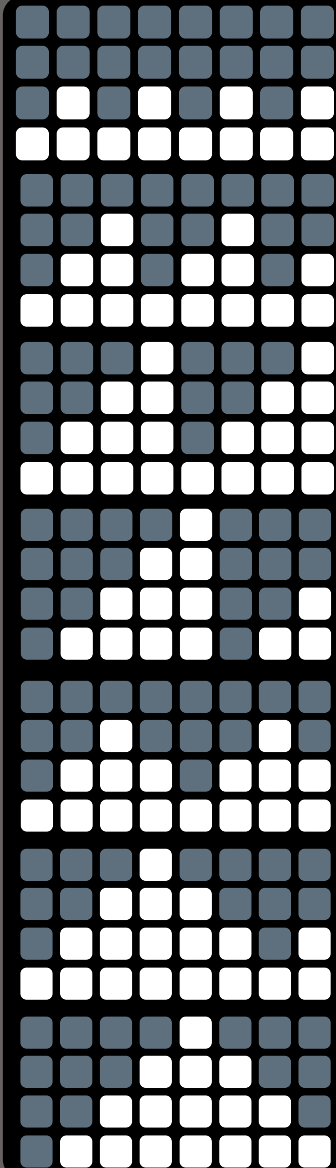

2-step

3-step

4-step

5-step

Push-pull in 4

Push-Pull in 6

Push-Pull in 8

No/Off Screen

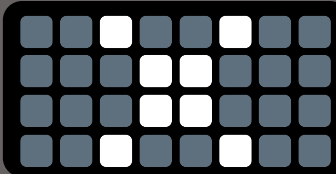

No/Off

32 | Screen Legend

32.04 - Trig Conditions

Trig Conditions			
	1 of 2		4 of 4
	2 of 2		1,2 of 4
	1 of 3		1,3 of 4
	2 of 3		1,4 of 4
	3 of 3		2,3 of 4
	1,2 of 3		2,4 of 4
	1,3 of 3		3,4 of 4
	2,3 of 3		1,2,3 of 4
	1 of 4		1,2,4 of 4
	2 of 4		1,3,4 fo 4
	3 of 4		2,3,4 of 4

32.05 - Edit Screens

Edit Screens

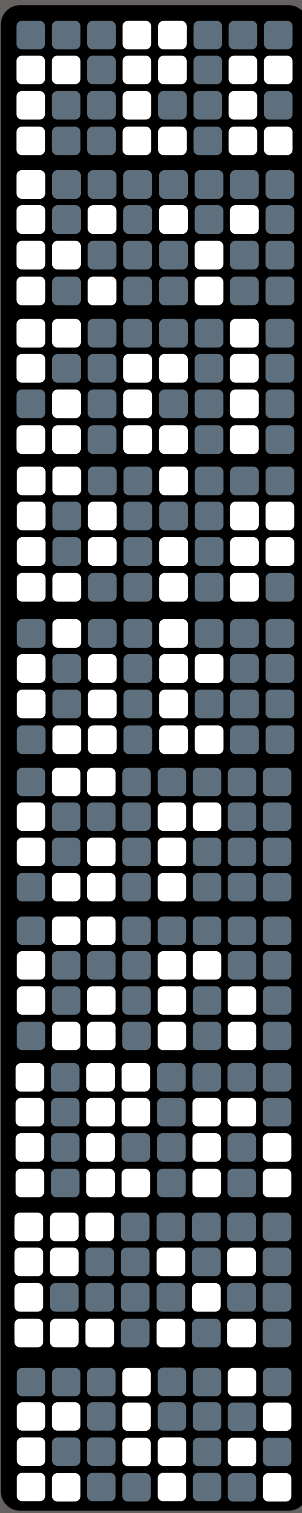
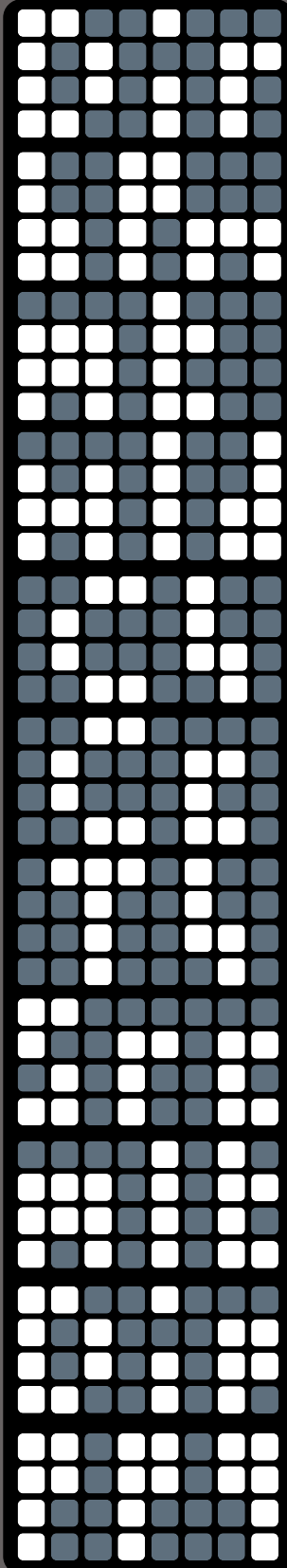

Direction Screen	Recall Screen
Tempo Screen	Key Screen
Mute Screen	Scale Screen
Hold Screen	Clock Division Screen
Midi Channel Screen	Quantize Screen
Midi Cc Screen	Groove Screen
Midi Thru Screen	Generate Pattern Screen
Clock Source Screen	Sequence Length Screen
Clock Out Multiplication Screen	Sequence Extend Screen
Clock Input Division Screen	Chance In Amount Screen
Midi PPQ Screen	

32 | Screen Legend

32.06 - Arp Octaves

Arp Octaves

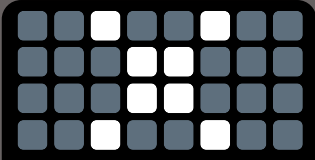
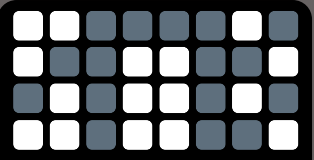
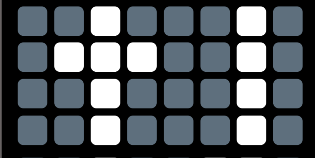
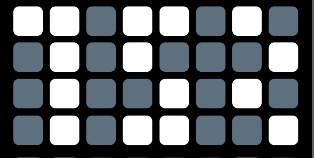
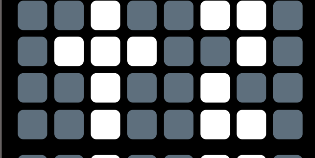
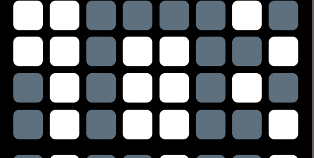
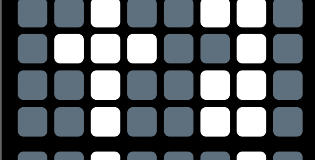
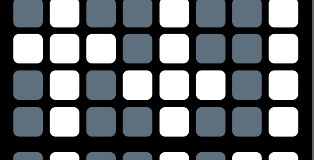
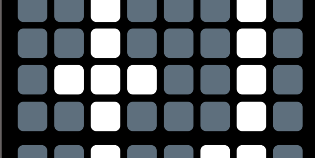
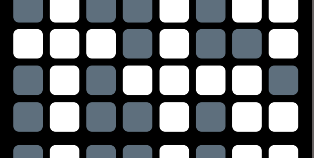
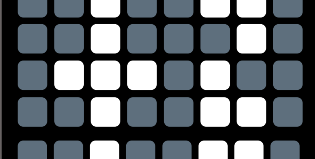
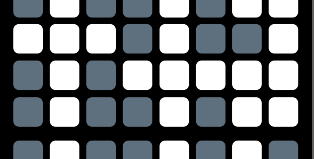
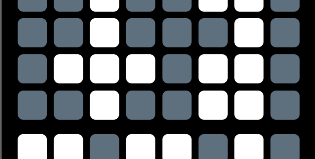
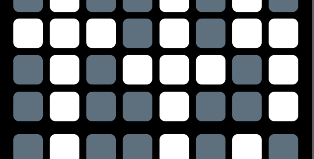
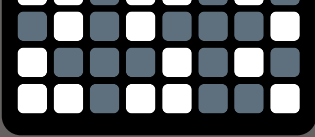
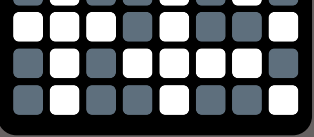
	Off		50% Random
	Up 1		75% Random
	Up 2		90% Random
	Up 3		Up/Down 1
	Down 1		Up/Down 2
	Down 2		Up/Down 3
	Down 3		Up/Down 4
	25% Random		Up/Down Random

32 | Screen Legend

32.07 - Arp Directions, Seq. Directions, Clock Sources

Arp Directions	
	Up/Down Inclusive
	Up/Down Exclusive
	Up 2 / Down 1
	Down/Up Inclusive
	Down/Up Exclusive
	Down 2 / Up 1
	As Played
	Random
	Stochastic Random

Seq. Directions	
	Forward
	Random
	Backward

Clock Sources	
	Forward
	Random
	Backward

32 | Screen Legend

32.08 - Generator Algorithms and Chords Voicings

Generator Algorithms

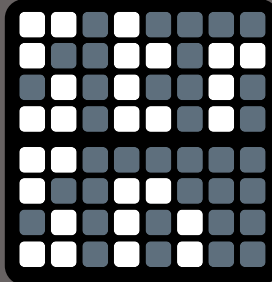

Straight Time
(Boots and Cats)

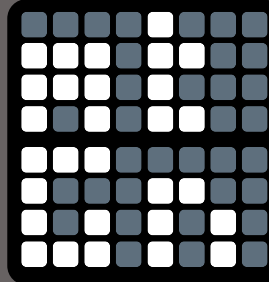

Mathy Time
(Luna's Favorite)

Syncopated Time
(Dance Hall)

Generative Time
(Algorithmic Meter)

Major Chords (Voicings 1-8)

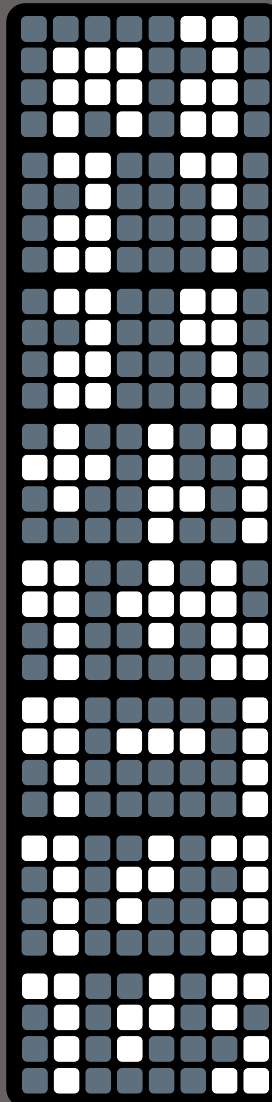

Major Triad
(1,3,5)

Major Seven
(1,3,5,7)

Major Nine
(1,3,5,7,9)

Major, Flat 7
(1,3,5, b 7)

Major Nine Six
(1,3,6,9)

Major 9, Rootless
(3,5,7,9)

Major 7, sharp 3
(1, \sharp 3,5,7)

Major 7, sharp 5
(1,3, \sharp 5,7)

Minor Chords (Voicings 9-16)

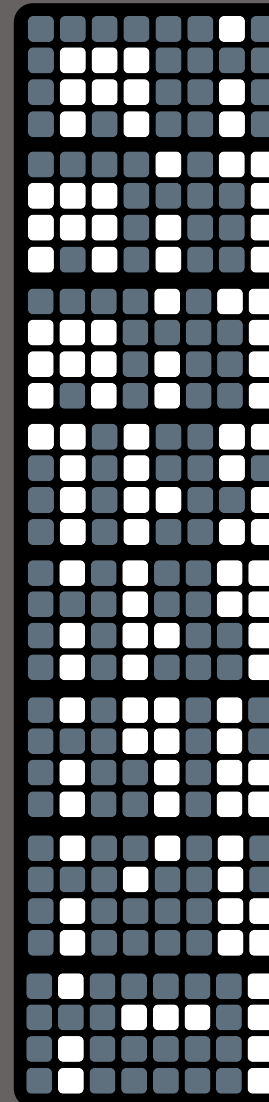

Minor Triad
(1, i 3,5)

Minor Seven
(1, i 3,5,7)

Minor Nine
(1, i 3,5,7,9)

Minor Seven, dim. 5
(1, i 3, b 5,7)

Minor dim. 9
(1, i 3,5,7, b 9)

Minor Nine Six
(1, i 3, i 6,9)

Minor 9, Sharp Six
(1, i 3, α 6,9)

Minor 9, Rootless
(i 3,5,7,9)

32 | Screen Legend

32.09 - Voice Modes and Scales

Voice Modes

	Straight Time (Boots and Cats)		Mathy Time (Luna's Favorite)
	Syncopated Time (Dance Hall)		Generative Time (Algorithmic Meter)

Scales

	Chromatic Scale		Minor Scale
	Major Scale		Whole Tone Scale
			Pentatonic Scale

33 | Factory Reset

33.01 - Digital Settings Reset

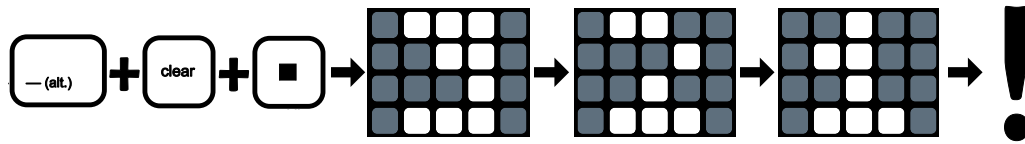

A **Digital Settings Reset** is used to reset all of Programm's settings without deleting any of your saved Sequences and Songs.

Perform a **Digital Settings Reset** by holding the [Alt. Button], [Clear Button], and [Stop Button] until the unit counts down from three. The unit will reset itself, and the **Digital Settings** will be restored to factory defaults.

33.02 - Full Factory Reset

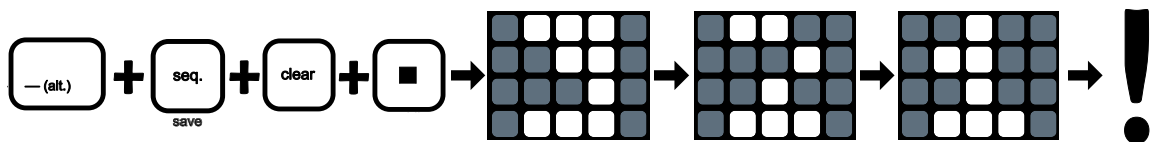

A **Full Factory Reset** is used to delete all of Programm's memory and return the unit to factory fresh condition.

Perform a **Full Factory Reset** by holding the [Alt. Button], [Seq. Button], [Clear Button], and [Stop Button] until the unit counts down from three. The unit will reset itself, and the unit will be fully reset to factory fresh settings.

34 | Firmware

34.01 - Firmware Revision Screen

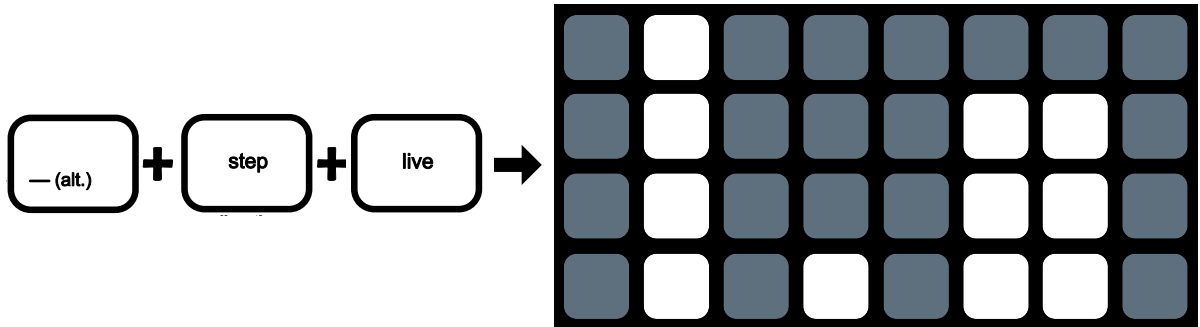

Hold the [Alt. Button], [Step Button], and [Live Button] to display the currently loaded Firmware Revision.

34.02 - Firmware Updates

Find the latest firmware for Programm on the Cre8Audio website : <https://www.cre8audio.com/>

35 | Warranty and Service

35.01 - Warranty

Cre8audio warrants to the original purchaser that this unit is free of defects in materials and workmanship under normal use and maintenance for a period of one (1) year from the date of original purchase. The warranty applies only to registered Cre8audio users that register their Cre8audio Product(s) within fourteen (14) days of time of original purchase. To register Cre8audio Products, visit Cre8audio.com. If the unit fails within the one (1) year period, it will be repaired, or replaced, at Cre8audio's option, at no charge, when returned prepaid to the Cre8audio Technical Service Center with proof of purchase – the sales receipt may be used for this purpose. Installation labor is not covered under this warranty.

Cre8audio reserves the right to change the method by which Cre8audio may provide warranty service, and any Cre8audio Product's eligibility to receive a particular method of service. Service will be limited to the options available in the country where service is requested. Service options, parts availability and response times may vary according to country. The original purchaser will be responsible for all shipping and handling charges. Customers that seek service in a country that is not the country of purchase must comply with all applicable import and export laws and regulations and be responsible for all custom duties, V.A.T. and other associated taxes and charges. For international service, Cre8audio may repair or replace Cre8audio Products and parts with comparable Cre8audio Products and parts that comply with local standards.

All replacement parts, whether new or re-manufactured, assume as their warranty period for only the remaining time of this warranty. This warranty does not apply to damage caused by improper use, accident, abuse, improper voltage service, fire, flood, lightning, or other acts of God, or if the product was altered or repaired by anyone other than Cre8audio Technical Service Center. Consequential and incidental damages are not recoverable under this warranty.

Some regions do not allow the exclusion or limitation of incidental or consequential damages, so the above limitation or exclusion may not apply. This warranty gives you specific legal rights, and you may also have other rights, which vary by state and country. No portion of this warranty may be copied or duplicated without the expressed written permission of Cre8audio. **THIS WARRANTY IS NOT TRANSFERABLE.**

35.02 - Service and Contact Information

Please contact us for service or other information related to Programm or any other Cre8audio product.
<https://www.cre8audio.com/supportticket>